

## GRES PORCELLANATO SMALTATO

FULL DEPTH VITRIFIED STONEWARE - GRÈS CERAME À TOUTE ÉPAISSEUR - FEINSTEINZEUG AUF GANZER DICKE - GRES PORCELÁNICO A TODO ESPESOR

**Residenziale, bagni, cucine, interni, esterni, scale, davanzali.  
Showrooms commerciali, alberghi, negozi, uffici, ristoranti.**



Housing, bathrooms,  
kitchens, interiors,  
exteriors, stairs,  
window ledges.

Zones résidentielles,  
salles de bains,  
cuisines, escaliers,  
rebords.

Wohnräume, Bäder,  
Küchen,  
Innen- und Außenräume,  
Treppen, Simse.

Chalets, cuartos de baño,  
cocinas, interiores,  
exteriores, escaleras,  
alféizares.

Sales showrooms, hotels,  
shops,  
offices, restaurants.

Showrooms commerciaux, hôtels,  
magasins,  
bureaux, restaurants.

Verkauf-Schauräume, Hotels,  
Geschäfte,  
Büros, Restaurants.

Salas de exposición comerciales,  
hoteles, tiendas,  
oficinas, restaurantes.

### RESISTENZA all'ABRASIONE

*Abrasion Resistance  
Résistance À L'abrasion  
Abriebfestkeit  
Resistencia A La Abrasión*

### RESISTENZA al GELO

*Frost Resistance  
Résistance Au Gel  
Frostbeständigkeit  
Resistencia Al Hielol*

### RESISTENZA ai CARICHI di ROTTURA

*Breaking Load Resistance  
Résistance Aux Charges De Rupture  
Bruchlastbeständigkeit  
Resistencia A Las Cargas De Ruptura*

### RESISTENZA agli ACIDI

*Acid Resistance  
Résistance Aux Acides  
Säurefestkeit  
Resistencia A Los Ácidos*

### RESISTENZA agli URTI

*Impact Strength  
Résistance Aux Chocs  
Schlagfestkeit  
Resistencia A Los Golpes*

### RESISTENZA alle MACCHIE

*Stain Resistance  
Résistance Aux Taches  
Fleckenbeständigkeit  
Resistencia A Las Manchas*



# AMALFI

45x45 18"x18"

SHADE SPECTRUM

Low  Moderate  High  Random

B.C.R.A.

dry ≥ 0,40

wet ≥ 0,40

FORMATO	SPESSORE	Pzx	Mqx	Kgx	Mqx	Kgx
45x45	9,5	5	1,01	24	34	34,34 / 816

BIANCO

BEIGE



45x45

53 53



45x45

53 53



Amalfi Fascia Bianco 7,5x45 119 6



Amalfi Fascia Beige 7,5x45 119 6



Amalfi Tozzetto 7,5x7,5

57 1 set x



Amalfi Tozzetto 7,5x7,5

57 1 set x

## Pezzi SPECIALI

Special trims - Piezas especiales - Sonderstücke - Piezas especiales

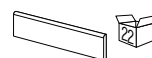

Battiscopa. 9x45 12

DISPONIBILE IN TUTTI I COLORI

Available in all colours - Disponible dans toutes les couleurs - In allen Farben erhältlich - Se comercializas en todos los colores

Beige 45x45 . Amalfi tozzetto





# ANTICHE DOGHE

15x60<sup>6</sup>x24".

SHADE SPECTRUM			
Low <input type="checkbox"/>	Moderate <input type="checkbox"/>	High <input type="checkbox"/>	Random <input type="checkbox"/>

DIN 51130	DIN 51097	ASTM C1028	B.C.R.A.
		dry ≥ 0,60 wet ≥ 0,60	dry ≥ 0,40 wet ≥ 0,40

FORMATO	SPESSORE	Pzx	Mqx	Kgx	Mqx	Kgx
15x60	10,3	12	1,08	24	44	47,52
						1076

A.D MIELE	A.D BIANCO	A.D NOCE	A.D GRIGIO	A.D CAFFÈ
15x60 	15x60 	15x60 	15x60 	15x60 
Mosaico 30x30 (2,5x15) 	Mosaico 30x30 (2,5x15) 	Mosaico 30x30 (2,5x15) 	Mosaico 30x30 (2,5x15) 	Mosaico 30x30 (2,5x15) 
A.D Miele Decoro 15x60 	A.D Bianco Decoro 15x60 	A.D Noce Decoro 15x60 	A.D Grigio Decoro 15x60 	A.D Caffè Decoro 15x60 



AD Grigio 15x60 nat.

### Pezzi SPECIALI

Special trims - Pieces especiales - Sonderstücke - Piezas especiales

● Battiscopa 7,5x60	● Gradone assemblato 15x60x3

● DISPONIBILE IN TUTTI I COLORI  
Available in all colours - Disponible dans toutes les couleurs - In allen Farben erhältlich - Se comercializas en todos los colores



15x60<sup>6</sup>x24".



AD Miele 15x60 nat.



AD Noce 15x60 nat.



AD Caffè 15x60 nat.



AD Bianco 15x60 nat.



# COUNTRY LIFE

20x80 8"x31,5".

SHADE SPECTRUM			
Low <input type="checkbox"/>	Moderate <input type="checkbox"/>	High <input type="checkbox"/>	Random <input type="checkbox"/>

DIN 51130	DIN 51097	ASTM C1028	B.C.R.A.
		dry ≥ 0,60 wet ≥ 0,60	dry ≥ 0,40 wet ≥ 0,40

FORMATO	SPESSORE	Pz x	Mqx	Kgx	Mqx	Kgx
20x80	10,3	7	1,12	25,08	42	1053,36

CL MIELE	CL BIANCO	CL TORTORA	CL NOCE
----------	-----------	------------	---------



20x80 nat.



20x80 nat.



20x80 nat.



20x80 nat.

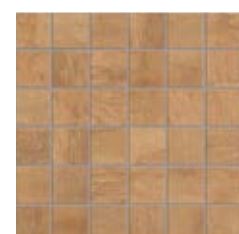

CL Miele Mosaico 30x30 (5x5)



CL Bianco Mosaico 30x30 (5x5)



CL Tortora Mosaico 30x30 (5x5)

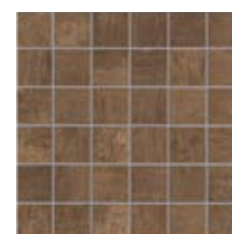

CL Noce Mosaico 30x30 (5x5)



CL Miele Muretto 20x80 nat.



CL Tortora Muretto 20x80 nat.



CL Bianco Muretto 20x80 nat.

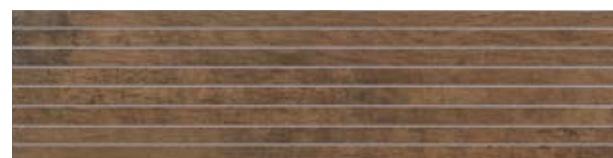

CL Noce Muretto 20x80 nat.



CL Rosone Country 80x80 € 253,00



CL Rosone Life 80x80 € 253,00



CL Bianco Fascia 20x80 nat.



CL Tortora Fascia 20x80 nat.



CL Miele Fascia 20x80 nat.



CL Noce Fascia 20x80 nat.

## Pezzi SPECIALI

Special trims - Pieces especiales - Sonderstücke - Piezas especiales



● Battiscopa 6,5x80

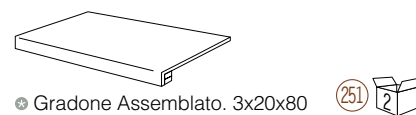

● Gradone Assemblato. 3x20x80

● DISPONIBILE IN TUTTI I COLORI  
Available in all colours - Disponible dans toutes les couleurs - In allen Farben erhältlich - Se comercializas en todos los colores



CLNoce 20x80 nat.



CLBianco 20x80 nat.  
CLBianco Fascia 20x80 nat.



CLTortora 20x80 nat.  
CLRosone Life 80x80



CLMiele 20x80 nat.  
CLMiele Muretto 20x80 nat.



# ELITE

80x80<sub>32"x32"</sub>. 40x80<sub>16"x32"</sub>. 60x60<sub>24"x24"</sub>. 30x60<sub>12"x24"</sub>.

CARRARA

SHADE SPECTRUM

Low <input type="checkbox"/>	Moderate <input checked="" type="checkbox"/>	High <input type="checkbox"/>	Random <input type="checkbox"/>

NATURALE DIN 51130	NATURALE DIN 51097	NATURALE ASTM C1028	NATURALE B.C.R.A.
<b>R9</b>	<b>A</b>	dry ≥ 0,60 wet ≥ 0,60	dry ≥ 0,40 wet ≥ 0,40

FORMATO	SPESSORE	Pzx	Mqx	Kgx	Mqx	Kgx
80x80	10,3	2	1,28	29,40	40	51,20
40x80	10,3	3	0,96	22,00	28	26,88
60x60	10,3	4	1,44	32,50	30	43,20
30x60	10,3	6	1,08	23,50	40	43,20



80x80 nat./rett.  
**177** **177**



40x80 nat./rett.  
**155** **155**

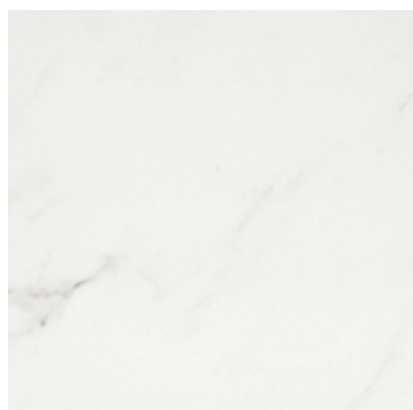

60x60 nat.  
**109** **109**

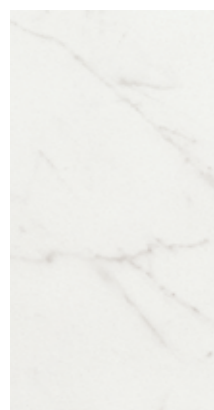

30x60 nat.  
**87** **87**



80x80 lapp./rett.  
**184** **184**

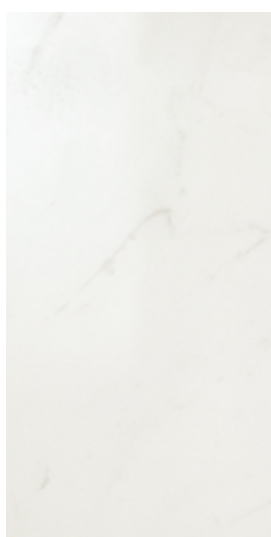

40x80 lapp./rett.  
**175** **175**



60x60 lapp./rett.  
**175** **175**



30x60 lapp./rett.  
**161** **161**

## Decori



Elite 40x80 lapp./rett. **190** **190** **3**



Elite 7,5x80 lapp./rett. **137** **4**



Listello 7,5x80 lapp./rett. **90** **16**



Matita 1,6x60 nat. **95** **4**



Listello Argento 1,5x60 nat. **121** **6**



Listello Bronzo 1,5x60 nat. **121** **6**



Dec. 30x60 nat. **143** **143** **6**

Dec. 30x60 lapp./rett. **177** **177** **6**



Listello 7,5x60 lapp./rett. **53** **16**



Tozzetto 7x7 lapp./rett. **9** **4**



Ang. Matita 1,6x1,6 **153** **2**



Torello 5x30 nat. **125** **6**



Ang. Torello 5x5 nat. **141** **2**



Mosaico (5x5) 30x30 nat. **195** **195** **5**



Mosaico 3D (7,5x7,5) 30x30 lapp./rett. **173** **5**



Esagona 10 30x30 nat./rett. **202** **202** **5**

## Pezzi SPECIALI

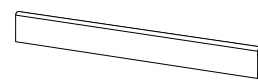

Battiscopa 7,5x80 nat./rett. **13** **10**

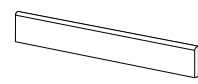

Battiscopa 7,5x60 nat. **12** **12**

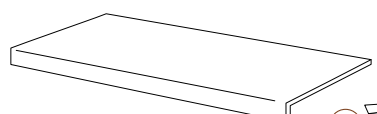

Gradone 3x33x80 nat. **257** **2**

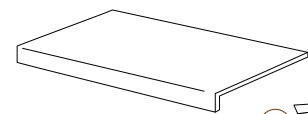

Gradone 3x33x60 nat. **233** **4**

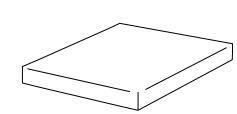

Ang Gradone 33x33 nat. **227** **2**

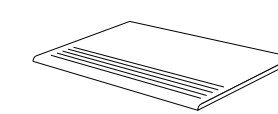

Step 30x60 nat. **141** **6**

**ELITE**80x80<sub>32"x32"</sub>. 40x80<sub>16"x32"</sub>. 60x60<sub>24"x24"</sub>. 30x60<sub>12"x24"</sub>.**PULPIS**

SHADE SPECTRUM			
Low <input type="checkbox"/>	Moderate <input checked="" type="checkbox"/>	High <input type="checkbox"/>	Random <input type="checkbox"/>

NATURALE	NATURALE	NATURALE	NATURALE
DIN 51130	DIN 51097	ASTM C1028	B.C.R.A.
<b>R9</b>	<b>A</b>	dry ≥ 0,60 wet ≥ 0,60	dry ≥ 0,40 wet ≥ 0,40

FORMATO	SPESSORE	Pzx	Mqx	Kgx	Mqx	Kgx
80x80	10,3	2	1,28	29,40	40	51,20
40x80	10,3	3	0,96	22,00	28	26,88
60x60	10,3	4	1,44	32,50	30	43,20
30x60	10,3	6	1,08	23,50	40	43,20

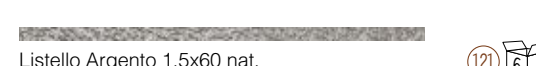
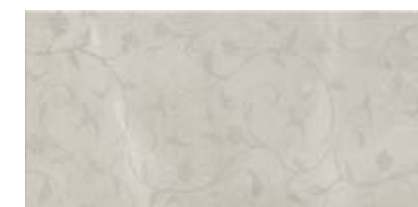
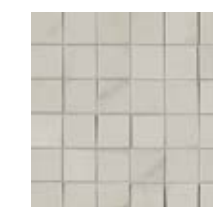
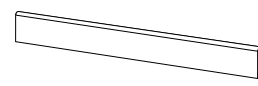
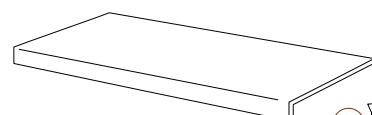
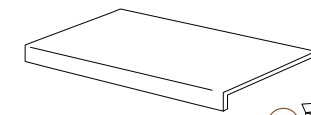
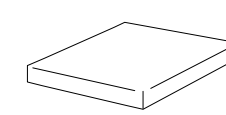
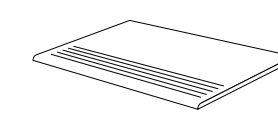
80x80 nat./rett.  
**177** **177**40x80 nat./rett.  
**155** **155**60x60 nat.  
**109** **109**30x60 nat.  
**87** **87**80x80 lapp./rett.  
**184** **184**40x80 lapp./rett.  
**175** **175**60x60 lapp./rett.  
**175** **175**30x60 lapp./rett.  
**161** **161****Decori** Special trims - Sonderstücke - Pieces speciales - Piezas especialesElite 40x80 lapp./rett. **190** **190** **3**Elite 7,5x80 lapp./rett. **137** **4**Listello 7,5x80 lapp./rett. **90** **16**Matita 1,6x60 nat. **95** **4**Listello Argento 1,5x60 nat. **121** **6**Listello Bronzo 1,5x60 nat. **121** **6**Dec. 30x60 nat. **143** **143** **6**Dec. 30x60 lapp./rett. **177** **177** **6**Listello 7,5x60 lapp./rett. **53** **16**Tozzetto 7x7 lapp./rett. **9** **4**Ang. Matita 1,6x1,6 **153** **2**Torello 5x30 nat. **125** **6**Ang. Torello 5x5 nat. **141** **2**Mosaico (5x5) 30x30 nat. **195** **195** **5**Mosaico 3D (7,5x7,5) 30x30 lapp./rett. **173** **5**Esagona 10 30x30 nat./rett. **202** **202** **5****Pezzi SPECIALI** Special trims - Pieces speciales - Sonderstücke - Piezas especialesBattiscopa 7,5x80 nat./rett. **13** **10**Battiscopa 7,5x60 nat. **12** **12**Gradone 3x33x80 nat. **257** **2**Gradone 3x33x60 nat. **233** **4**Ang Gradone 33x33 nat. **227** **2**Step 30x60 nat. **141** **6**



**ELITE**80x80<sup>32"x32"</sup>. 40x80<sup>16"x32"</sup>. 60x60<sup>24"x24"</sup>. 30x60<sup>12"x24"</sup>.**SEGESTA**

SHADE SPECTRUM			
Low <input type="checkbox"/>	Moderate <input checked="" type="checkbox"/>	High <input type="checkbox"/>	Random <input type="checkbox"/>

NATURALE	NATURALE	NATURALE	NATURALE
DIN 51130	DIN 51097	ASTM C1028	B.C.R.A.
<b>R9</b>	<b>A</b>	dry ≥ 0,60 wet ≥ 0,60	dry ≥ 0,40 wet ≥ 0,40

FORMATO	SPESSORE	Pz x	Mqx	Kgx	x	Mqx	Kgx
80x80	10,3	2	1,28	29,40	40	51,20	1176
40x80	10,3	3	0,96	22,00	28	26,88	618
60x60	10,3	4	1,44	32,50	30	43,20	975
30x60	10,3	6	1,08	23,50	40	43,20	940

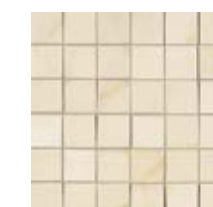
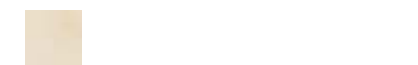
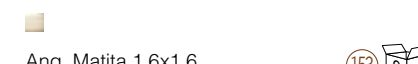
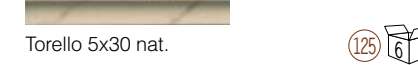
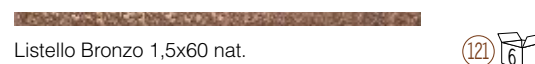
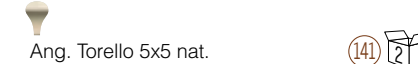
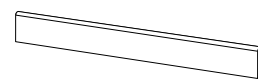
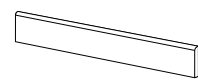
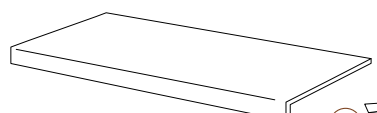
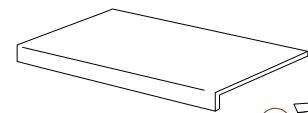
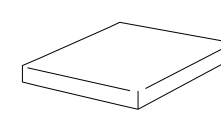
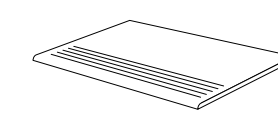
80x80 nat./rett.  
**177** **177**40x80 nat./rett.  
**155** **155**60x60 nat.  
**109** **109**30x60 nat.  
**87** **87**80x80 lapp./rett.  
**184** **184**40x80 lapp./rett.  
**175** **175**60x60 lapp./rett.  
**175** **175**30x60 lapp./rett.  
**161** **161****Decori** Special trims - Sonderstücke - Pieces especiales - Piezas especialesElite 40x80 lapp./rett. **190** **190** Dec. 30x60 nat. **143** **143**   
Dec. 30x60 lapp./rett. **177** **177** Mosaico (5x5)  
30x30 nat. **195** **195** Elite 7,5x80 lapp./rett. **137** Listello 7,5x60 lapp./rett. **53** Mosaico 3D (7,5x7,5)  
30x30 lapp./rett. **173** Listello 7,5x80 lapp./rett. **90** Tozzetto 7x7 lapp./rett. **9** Matita 1,6x60 nat. **95** Ang. Matita 1,6x1,6 **153** Listello Argento 1,5x60 nat. **121** Torello 5x30 nat. **125** Listello Bronzo 1,5x60 nat. **121** Ang. Torello 5x5 nat. **141** Esagona 10  
30x30 nat./rett. **202** **202** **Pezzi SPECIALI** Special trims - Pieces especiales - Sonderstücke - Piezas especialesBattiscopa 7,5x80 nat./rett. **13** Battiscopa 7,5x60 nat. **12** Gradone 3x33x80 nat. **257** Gradone 3x33x60 nat. **233** Ang Gradone 33x33 nat. **227** Step 30x60 nat. **141**

80x80<sup>32"x32"</sup>. 40x80<sup>16"x32"</sup>. 60x60<sup>24"x24"</sup>. 30x60<sup>12"x24"</sup>.



pav: Carrara 80x80 nat./rett.  
riv: Carrara Elite 40x80 lapp./rett. - 40x80 lapp./rett. - listello argento 1,5x60 nat.



riv: Carrara Elite 40x80 lapp./rett.



pav: Carrara 80x80 nat./rett.  
riv: Carrara 40x80 lapp./rett. - listello argento 1,5x60 nat.

80x80<sub>32"x32"</sub>. 40x80<sub>16"x32"</sub>. 60x60<sub>24"x24"</sub>. 30x60<sub>12"x24"</sub>.



pav: Carrara 40x80 nat./rett. - Pulpis Esagona10 30x30 nat./rett.  
riv: Pulpis 40x80 lapp./rett. - Elite 40x80 lapp./rett.



pav: Pulpis Esagona10 30x30 nat./rett.  
riv: Pulpis 40x80 lapp./rett. - Elite 40x80 lapp./rett.

80x80<sup>32"x32"</sup>. 40x80<sup>16"x32"</sup>. 60x60<sup>24"x24"</sup>. 30x60<sup>12"x24"</sup>.



pav: Segesta 60x60 nat.  
riv: Segesta Mosaico3D 30x30 lapp./rett.



pav: Segesta 30x60 nat.  
riv: Segesta 30x60 lapp./rett. - Listello Bronzo 1,5x60 nat.



# MADERA

20x80 8"x31,5".

SHADE SPECTRUM			
Low <input type="checkbox"/>	Moderate <input type="checkbox"/>	High <input type="checkbox"/>	Random <input type="checkbox"/>

DIN 51130	DIN 51097	ASTM C1028	B.C.R.A.	D.C.O.F.
<b>R10</b>	<b>B</b>	dry ≥ 0,60 wet ≥ 0,60	dry ≥ 0,40 wet ≥ 0,40	wet ≥ 0,42

FORMATO	SPESSORE	Pzx	Mqx	Kgx	Mqx	Kgx
20x80	10,3	7	1,12	25,08	42	1053,36

**MA BIANCO**      **MA CENERE**      **MA ROVERE**      **MA PERLA**



20x80 nat. (101) (101)      MA decoro 20x80 nat. (157) (157)      20x80 nat. (101) (101)      MA decoro 20x80 nat. (157) (157)      20x80 nat. (101) (101)      MA decoro 20x80 nat. (157) (157)      20x80 nat. (101) (101)      MA decoro 20x80 nat. (157) (157)



MA Bianco Mosaico 20x20 (202) (202) (16)      MA Cenere Mosaico 20x20 (202) (202) (16)      MA Rovere Mosaico 20x20 (202) (202) (16)      MA Perla Mosaico 20x20 (202) (202) (16)



MA Bianco Muretto 20x40 (200) (200) (16)      MA Cenere Muretto 20x40 (200) (200) (16)      MA Rovere Muretto 20x40 (200) (200) (16)      MA Perla Muretto 20x40 (200) (200) (16)



MA MIX Mosaico 20x20 (202) (202) (16)      MA MIX Muretto 20x40 (200) (200) (16)



MA BLENDED 20x80 naturale

## Blended

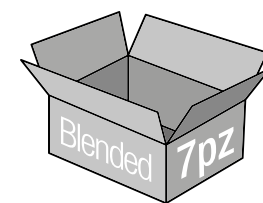

MA Blended 20x80 nat (7 pezzi) (159) (159)

2 pz. MA Perla 20x80 nat  
2 pz. MA Rovere 20x80 nat  
2 pz. MA Cenere 20x80 nat  
1 pz. MA Bianco 20x80 nat

## Pezzi SPECIALI

Special trims - Pieces speciale - Sonderstücke - Piezas especiales

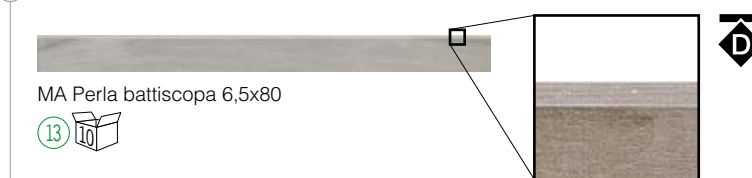

MA Perla battiscopa 6,5x80 (13) (16)



MA Cenere battiscopa 6,5x80 (13) (16)



MA Rovere battiscopa 6,5x80 (13) (16)



MA Bianco battiscopa 6,5x80 (13) (16)

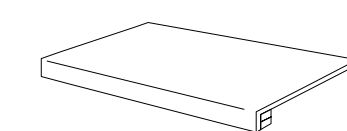

Gradone Assemblato. 3x20x80 (251) (2)

● **DISPONIBILE IN TUTTI I COLORI**  
Available in all colours.  
Disponibile dans toutes les couleurs.  
In allen Farben erhältlich.  
Se comercializas en todos los colores.



MABIANCO  
20x80 naturale



MACENERE  
20x80 naturale



MABIANCO  
20x80 naturale



MACENERE  
20x80 naturale



# MARMI ANTICHI

45x45<sup>18"x18"</sup>.30x30<sup>12"x12"</sup>.15x15<sup>6"x6"</sup>.10x10<sup>4"x4"</sup> Modular System

SHADE SPECTRUM			
Low <input type="checkbox"/>	Moderate <input type="checkbox"/>	High <input type="checkbox"/>	Random <input type="checkbox"/>

ASTM C1028
dry ≥ 0,60
wet ≥ 0,60

FORMATO	SPESSORE	Pz x	Mqx	Kgx		Mqx	Kgx
45x45	9,5	5	1,01	21,50	34	34,34	731
30x30	10	13	1,17	25,00	40	46,80	1000
15x15	9	48	1,08	24,50	60	64,80	1470
10x10	10	80	0,80	16,40	60	48,00	984
Modular	10	15	1,01	21,50	34	34,34	731

REALE	ANTICO	CLASSICO	ALABASTRO
-------	--------	----------	-----------

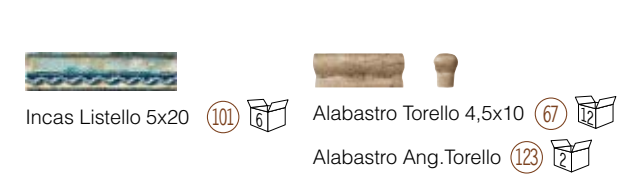
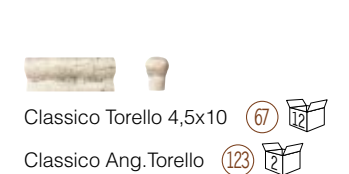
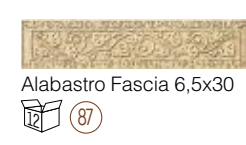
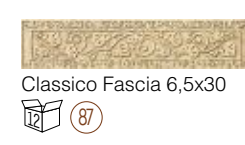
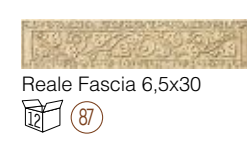
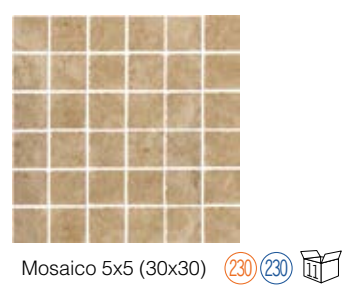
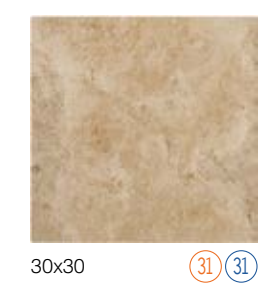
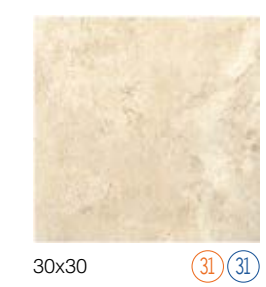
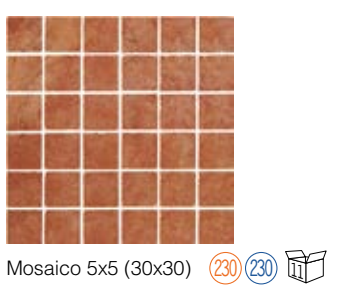
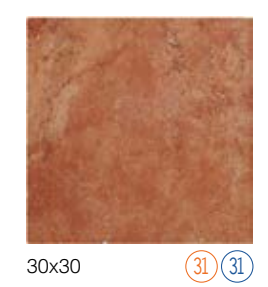
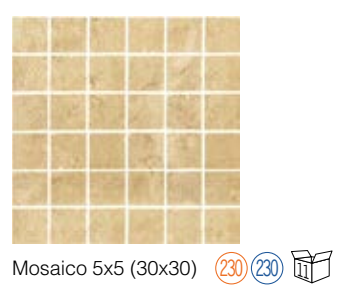
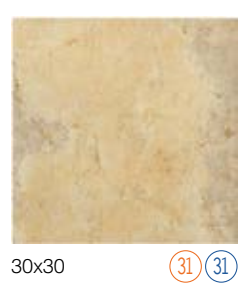
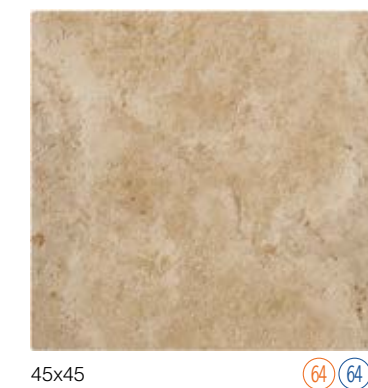
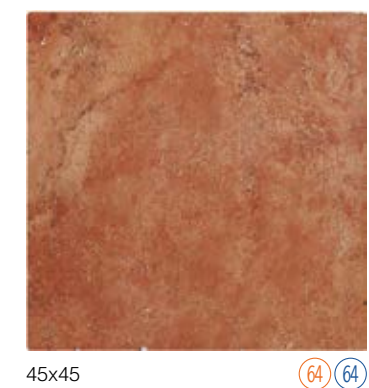
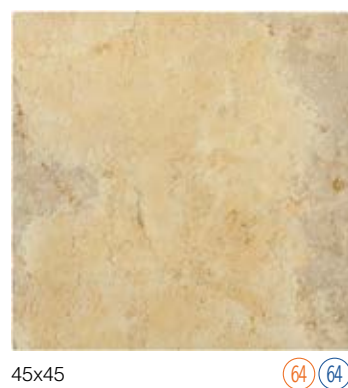

## Pezzi SPECIALI

Special trims - Piezas especiales - Sonderstücke - Piezas especiales

Gradino. 30x30 NAT. <span>73</span>	Battiscopa. 7,2x30 NAT. <span>9</span>	V-cap. 5,5x15 <span>43</span>	V-cap. ang. h. 5,5 <span>93</span>	QR outside. 3x15 <span>37</span>	Beak outside <span>89</span>	SBN 15 <span>29</span>	DBN 15 <span>37</span>

● DISPONIBILE IN TUTTI I COLORI  
Available in all colours - Disponible dans toutes les couleurs - In allen Farben erhältlich - Se comercializas en todos los colores

## Modular SYSTEM

**BREVETTATO**

SPECIALE CONFEZIONE MODULARE A 15 PEZZI!  
Special Modular packaging 15 pcs.  
Emballage special 15 pcs.  
Sonder Verpackung 15 stück.  
Embalaje especial modular con 15 piezas.

3 Pz. 45x45  
2 Pz. 30x30  
10 Pz. 15x15

91 91



# MARMI ANTICHI

45x45<sup>18"x18"</sup>.30x30<sup>12"x12"</sup>.15x15<sup>6"x6"</sup>.10x10<sup>4"x4"</sup> Modular System



Reale 45x45 . mosaico . Classico 45x45



# MARMI ANTICHI

45x45<sup>18"x18"</sup>.30x30<sup>12"x12"</sup>.15x15<sup>6"x6"</sup>.10x10<sup>4"x4"</sup> Modular System



Alabastro 30x30  
Alabastro 15x15 . Alabastro inserto . vcap



Classico 30x30 . Classico fascia . Alabastro 30x30



Reale 10x10 . Reale torelio . Incas decoro . Incas listello



# PATINA

30x120<sup>12"x48"</sup>.20x80<sup>8"x31,5"</sup>.

## SHADE SPECTRUM

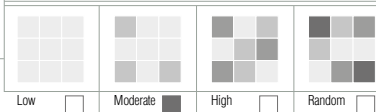

FORMATO	SPESSORE	Pz x	Mqx	Kgx	x	Mqx	Kgx
30x120	10,3	3	1,08	25,00	30	32,40	750,00
20x80	10,3	7	1,12	25,08	42	47,04	1053,36

### PA GRIGIO

### PA BEIGE

### PA CASTANO



30x120 nat. (149) (149)



20x80 nat. (101) (101)  
20x80 grip (117) (117)



decoro 20x80 nat. (161) (161)



muretto 20x80 nat. (187) (187)



30x120 nat. (149) (149)



20x80 nat. (101) (101)  
20x80 grip (117) (117)



decoro 20x80 nat. (161) (161)



muretto 20x80 nat. (187) (187)



30x120 nat. (149) (149)



20x80 nat. (101) (101)  
20x80 grip (117) (117)



decoro 20x80 nat. (161) (161)



muretto 20x80 nat. (187) (187)

## Pezzi SPECIALI

Special trims - Peces especiales - Sonderstücke - Piezas especiales

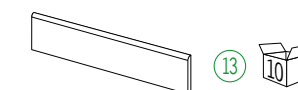

\* Battiscopa 6,5x80



\* Gradone Assemblato. 3x20x120 nat.

\* DISPONIBILE IN TUTTI I COLORI  
Available in all colours - Disponible dans toutes les couleurs  
In allen Farben erhältlich - Se comercializas en todos los colores



# PATINA

30x120<sup>12"x48"</sup>. 20x80<sup>8"x31.5"</sup>.



out: PA Grigio 20x80 grip - in: PA Grigio 20x80 nat. - PA Grigio 30x120 nat.



PA Castano 20x80 nat. - PA Beige 20x80 nat. - PA Beige decoro 20x80 nat.



# PATINA

30x120<sup>12"x48"</sup>.20x80<sup>8"x31,5"</sup>.





# TERRE SENESI

30x30<sup>12"x12"</sup>. 15x30<sup>6"x12"</sup>

SHADE SPECTRUM

Low  Moderate  High  Random

DIN 51130



FORMATO	SPESSORE	Pzx	Mqx	Kgx	Mqx	Kgx
30x30	8,5	15	1,35	23,60	40	54,00
15x30	8,5	26	1,20	21,80	60	72,00
						944
						1308

## CETONA



PEI IV 30x30 (26) (26)



6x6



## MONTALCINO



PEI IV 30x30 (26) (26)



PEI IV 15x30 (37) (37)



6x6



Piensa Fascia 6x30



Piensa Tozz. 6x6



Piensa Fascia 6x30



Piensa Tozz. 6x6



## Pezzi SPECIALI

Special trims - Píeces especiales - Sonderstücke - Piezas especiales

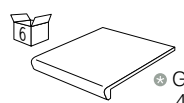

Gradone pressato 4x33x30 (173)

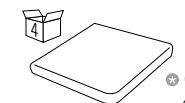

Gradone Ang. pressato 4x33x33 (203)

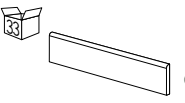

Battiscopa 8x30 (9)

DISPONIBILE IN TUTTI I COLORI  
Available in all colours - Disponible dans toutes les couleurs - In allen Farben erhältlich - Se comercializas en todos los colores



Montalcino 30x30 . 15x30 .Piensa fascia



# WALNUT

30x120 12"x48"

## SHADE SPECTRUM

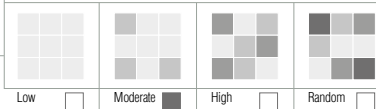

FORMATO	SPESSORE	Pzx	Mqx	Kgx	Mqx	Kgx
30x120	10,3	3	1,08	25,00	30	32,40
						750

### 120 BEIGE



30x120 nat.

149 149

30x120 ret.

159 159

### 120 GRIGIO



30x120 nat.

149 149

30x120 ret.

159 159

### 120 NOCE



30x120 nat.

149 149

30x120 ret.

159 159

## Pezzi SPECIALI

Special trims - Pieces especiales - Sonderstücke - Piezas especiales

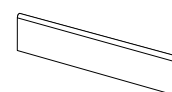

• Battiscopa 6,5x120

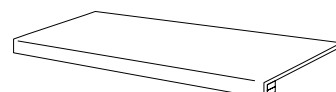

• Gradone Assemblato. 3x20x120 nat.

• Gradone Assemblato. 3x20x120 ret.



• DISPONIBILE IN TUTTI I COLORI

Available in all colours - Disponible dans toutes les couleurs  
In allen Farben erhältlich - Se comercializas en todos los colores



120 Grigio 30x120 nat.



# WALNUT

30x120<sup>12"x48"</sup>



120 Beige 30x120 nat. - 120 Noce 30x120 nat.



120 Beige 30x120 ret.





 pastorelli

## TREVI



**Colorforte Formella\***

10x20

\* 2 soggetti assortiti



20x20



**Manarola Decoro**  
20x20



**Atrani Decoro**  
20x20

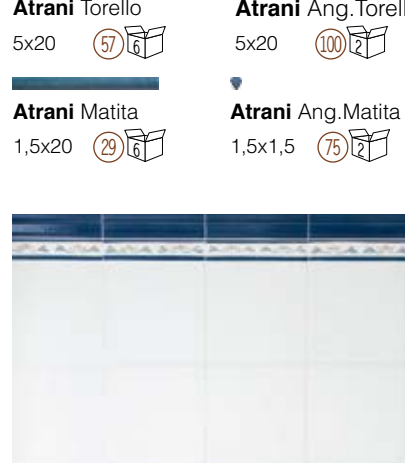

**Atrani Listello**  
4x20

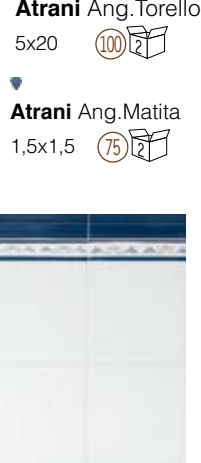

**Atrani Torello**  
5x20



**Atrani Matita**  
1,5x20



**Atrani Ang. Torello**  
5x20



**Atrani Ang. Matita**  
1,5x1,5



**Cefalù Formella\***

10x20



**Trevi Torello**  
5x20

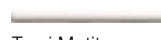

**Trevi Matita**  
1,5x20



**Trevi Ang. Torello**  
5x5



**Trevi Ang. Matita**  
1,5x1,5



**Navelli Decoro**  
20x20



Trevi 20x20  
Manarola Decoro 20x20



Atrani Decoro 20x20  
Trevi 20x20  
Atrani Torello  
Atrani Listello



# TAILORMADE

28x56<sup>11"x22"</sup>

SHADE SPECTRUM

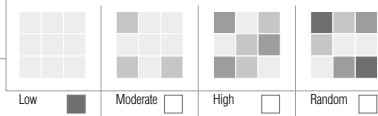

FORMATO	SPESSORE	Pzx	Mqx	Kgx	Mqx	Kgx
28x56	10	5	0,784	14,90	52	40,76
30x30	10,5	12	1,08	24,00	40	47,52
						774,80
						1077,00

TM10 BIANCO

TM20 BEIGE

TM05 GRIGIO

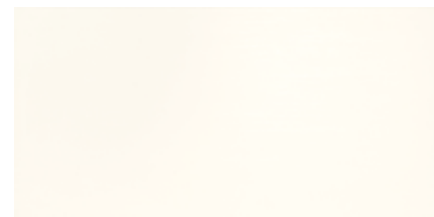

28x56 nat.

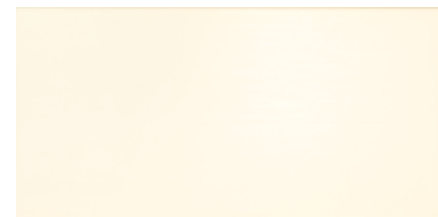

28x56 nat.



28x56 nat.



mosaico 5.10  
28x28 (tessera 2,8x7)



dec provenzale 28x56 nat.



dec provenzale 28x56 nat.



dec provenzale 28x56 nat.

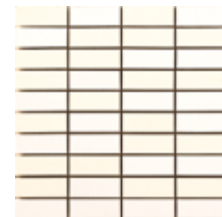

mosaico 10.20  
28x28 (tessera 2,8x7)



fascia provenzale  
25,5x3,5 nat.



fascia provenzale  
25,5x3,5 nat.



fascia provenzale  
25,5x3,5 nat.



fascia mix brown  
30x2,5 nat.



fascia mix grey  
30x2,5 nat.



SHADE SPECTRUM

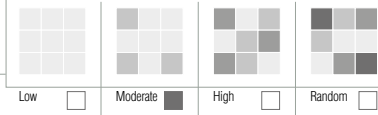

# TAILORMADE

30x30<sup>12"x12"</sup>

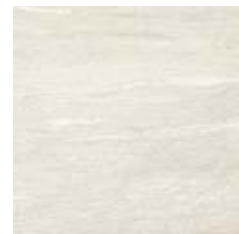

30x30 nat.

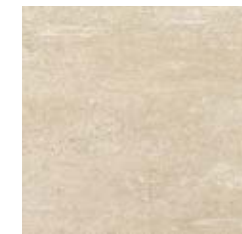

30x30 nat.

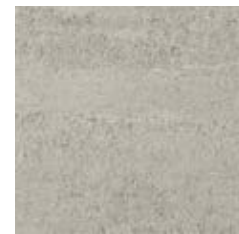

30x30 nat.



30x30 nat.

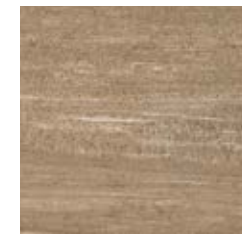

30x30 nat.

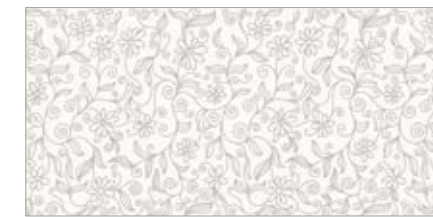

wallpaper 28x56 nat.

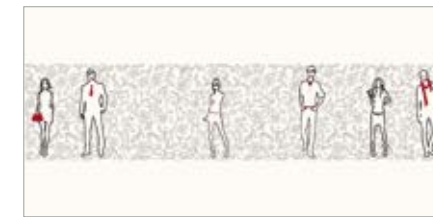

fascia people 28x56 nat.

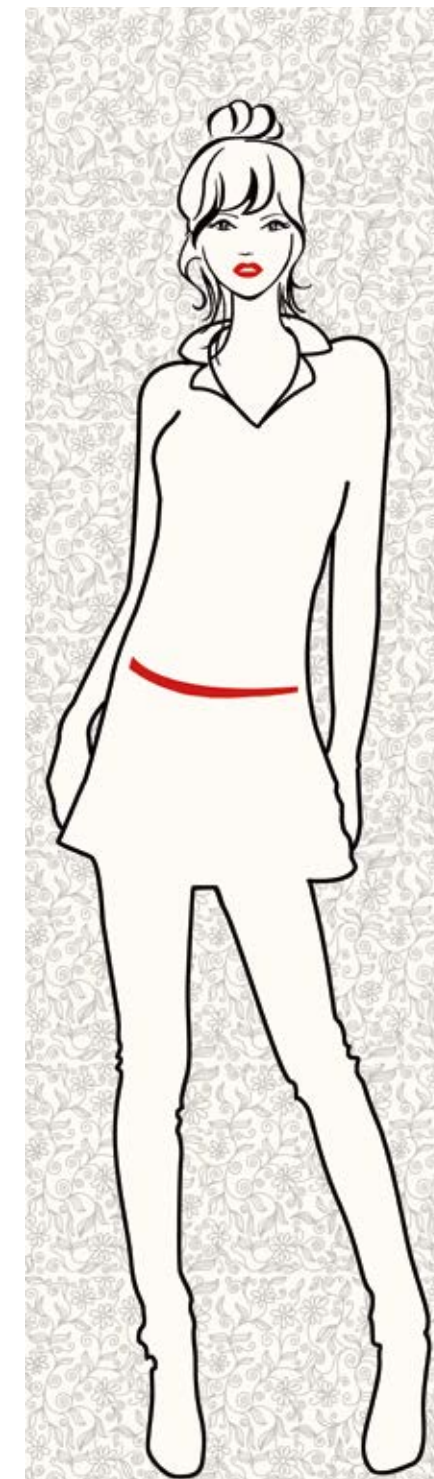

TM10 girl 196x56



(€ 615,00) 1 set

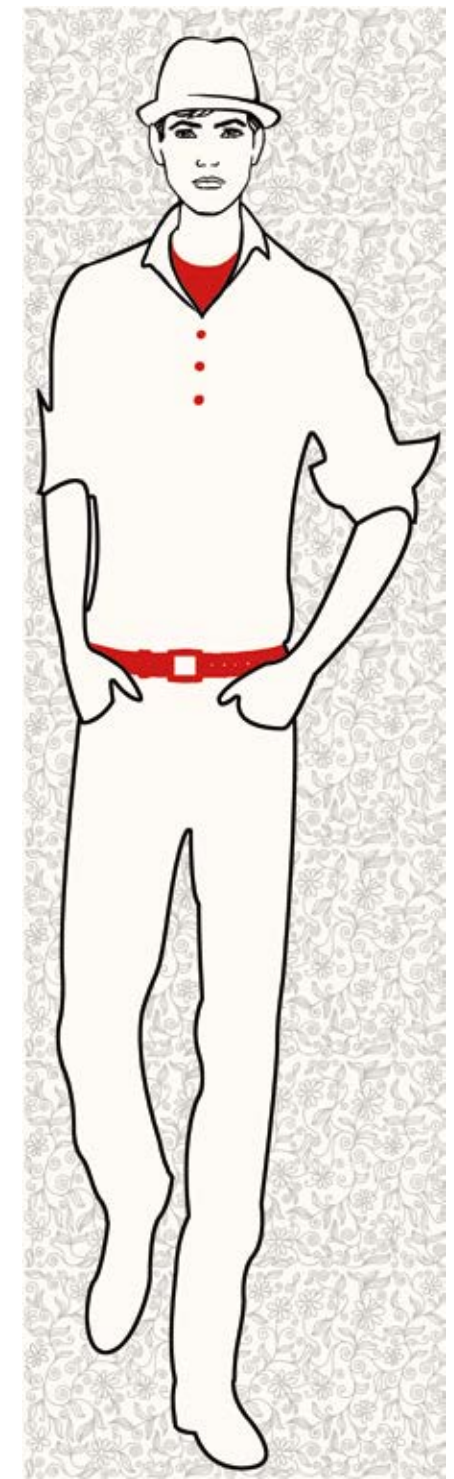

TM10 boy 196x56



(€ 615,00) 1 set

● DISPONIBILE NEI COLORI:  
 TM10bianco e TM20beige  
 Available in the colors: TM10bianco - TM20beige  
 Disponibles dans les couleurs: TM10bianco - TM20beige  
 In den Farben lieferbar: TM10bianco - TM20beige  
 Disponible en colores: TM10bianco - TM20beige

TM mosaico 5.10



TM 10 Bianco 28x56 nat. TM fascia Mix Grey . TM 05 Grigio 28x56 nat.



TM 10 28x56 nat . TM 10 fascia People 28x56 nat.



## GRES PORCELLANATO A TUTTO SPESSORE

FULL DEPTH VITRIFIED STONEWARE - GRÈS CERAME À TOUTE ÉPAISSEUR - FEINSTEINZEUG AUF GANZER DICKE - GRES PORCELÁNICO A TODO ESPESOR

**Pavimenti industriali resistenti al carico.  
Pavimenti per uffici.**



Load resistant industrial flooring.

Office flooring.

Carrelages industriels résistants aux charges.

Carrelages pour bureaux.

Belastbare Industrieböden.

Büroböden.

Pavimentos industriales resistentes a la carga.

Pavimentos para oficina.

### RESISTENZA all'ABRASIONE

*Abrasion Resistance  
Résistance À L'abrasion  
Abriebfestkeit  
Resistencia A La Abrasión*

### RESISTENZA al GELO

*Frost Resistance  
Résistance Au Gel  
Frostbeständigkeit  
Resistencia Al Hielo*

### RESISTENZA ai CARICHI di ROTTURA

*Breaking Load Resistance  
Résistance Aux Charges De Rupture  
Bruchlastbeständigkeit  
Resistencia A Las Cargas De Ruptura*

### RESISTENZA agli ACIDI

*Acid Resistance  
Résistance Aux Acides  
Säurefestkeit  
Resistencia A Los Ácidos*

### RESISTENZA agli URTI

*Impact Strength  
Résistance Aux Chocs  
Schlagfestkeit  
Resistencia A Los Golpes*

### RESISTENZA alle MACCHIE

*Stain Resistance  
Résistance Aux Taches  
Fleckenbeständigkeit  
Resistencia A Las Manchas*

pastorelli

# TRADIZIONALE

30x30<sup>12"x12"</sup>. **PORFIRIZZATO** *unpolished.matt.mat.natural*

SHADE SPECTRUM

Low <input type="checkbox"/>	Moderate <input checked="" type="checkbox"/>	High <input type="checkbox"/>	Random <input type="checkbox"/>

FORMATO	SPESSORE	Pz x	Mqx	Kgx		Mqx	Kgx
30x30	8,5	15	1,35	24,70	40	54,00	988,00

DIASPRO.08

DIAMANTE.12



30x30 nat. 8,5 mm



30x30 nat. 8,5 mm



## Pezzi SPECIALI

Special trims - Piezas especiales - Sonderstücke - Piezas especiales



● Gradino. 30x30 NAT. **49**

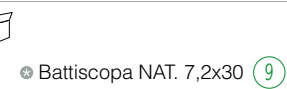

● Battiscopa NAT. 7,2x30 **9**

● DISPONIBILE IN TUTTI I COLORI

Available in all colours - Disponible dans toutes les couleurs - In allen Farben erhältlich - Se comercializas en todos los colores

# pastorelli WallPaper

Pastorelli Wallpaper rappresenta il massimo livello del design e della tecnologia applicata alla decorazione artistica su carta delle pareti. Vere opere d'arte, realizzate da artisti e designer, caratterizzate da un grande livello di profondità e realismo.

Le collezioni Pastorelli Wallpaper sono realizzate con materiali completamente ecologici e sono concepite per essere abbinare ai pavimenti e rivestimenti ceramici Pastorelli. Il risultato è un incredibile effetto artistico-decorativo per tutti gli ambienti.

*Pastorelli Wallpaper represents the highest level of design and technology applied to artistic decoration on wallpaper. Pure art masterpieces, realized by artists and designers, characterized by a high level of depth and realism.*

*Pastorelli wallpaper collections are realized with fully eco materials and are imagined to be combined with wall and floor Pastorelli products. The result is an amazing artistic-decorative effect for all environments.*

*Pastorelli Wallpaper représente le plus haut niveau de la conception et de la technologie appliquée à la décoration artistique sur papier peint. De véritables œuvres d'art, créées par des artistes et designers, caractérisées par un grand niveau de profondeur et de réalisme.*

*Les collections Pastorelli Wallpaper sont fabriqués avec des matériaux entièrement écologique et sont conçus pour être combinés avec le carrelage Pastorelli. Le résultat est un effet décoratif artistique incroyable pour tous les environnements.*

*Pastorelli Paper zeigt die höchste Stufe von Design, Technologie und künstlerische Dekoration auf Tapeten. Wahre Kunstwerke, geschaffen von Künstlern und Designern, gekennzeichnet durch einen hohen Grad an Tiefe und Realismus.*

*Die Kollektionen Pastorelli Paper werden mit absolut umweltfreundlichen Materialien hergestellt und sind für die Kombination mit Wand- und Bodenserien von Pastorelli konzipiert. Das Ergebnis ist eine unglaublich künstlerische und dekorative Wirkung für alle Ansprüche.*

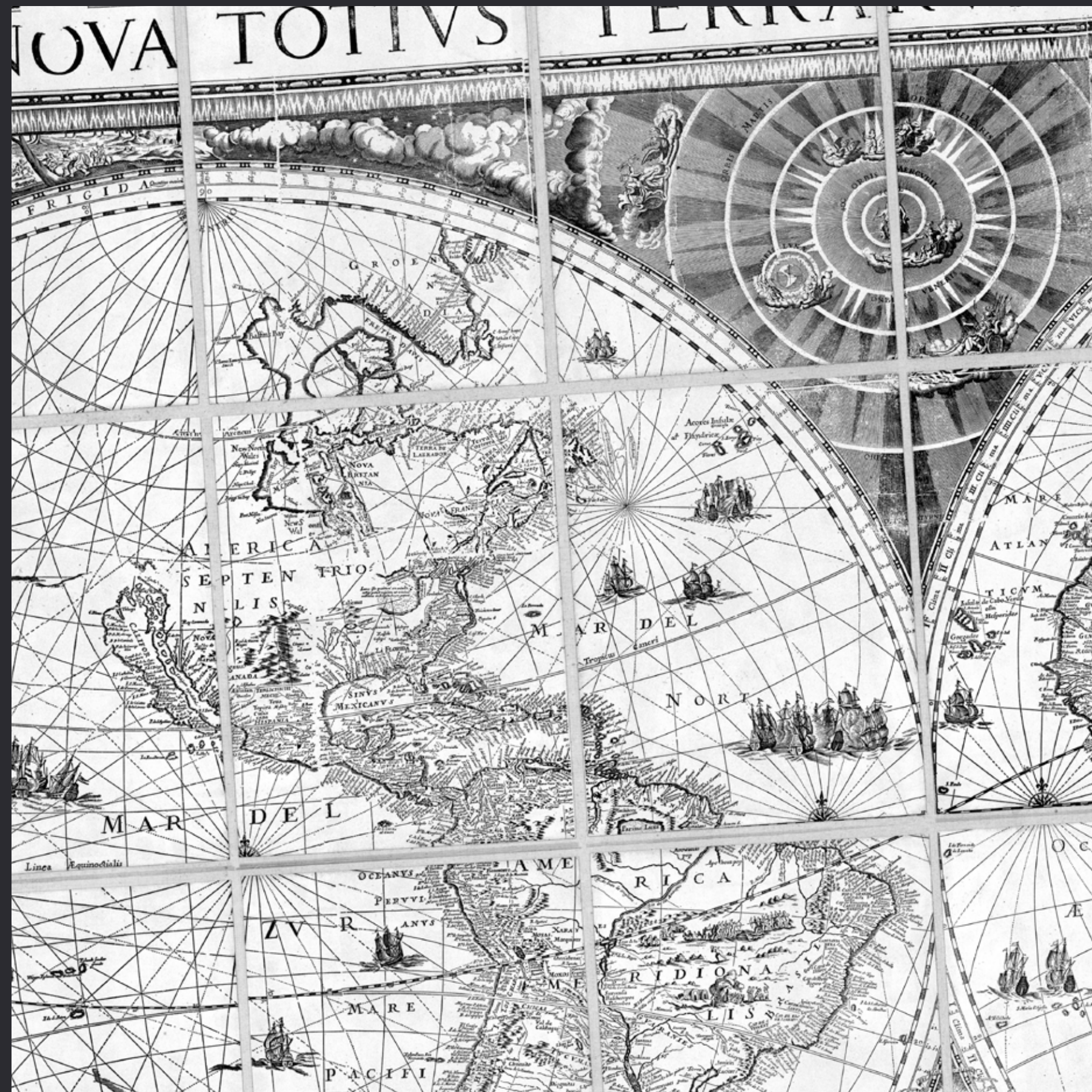

Total size: 584x290 cm

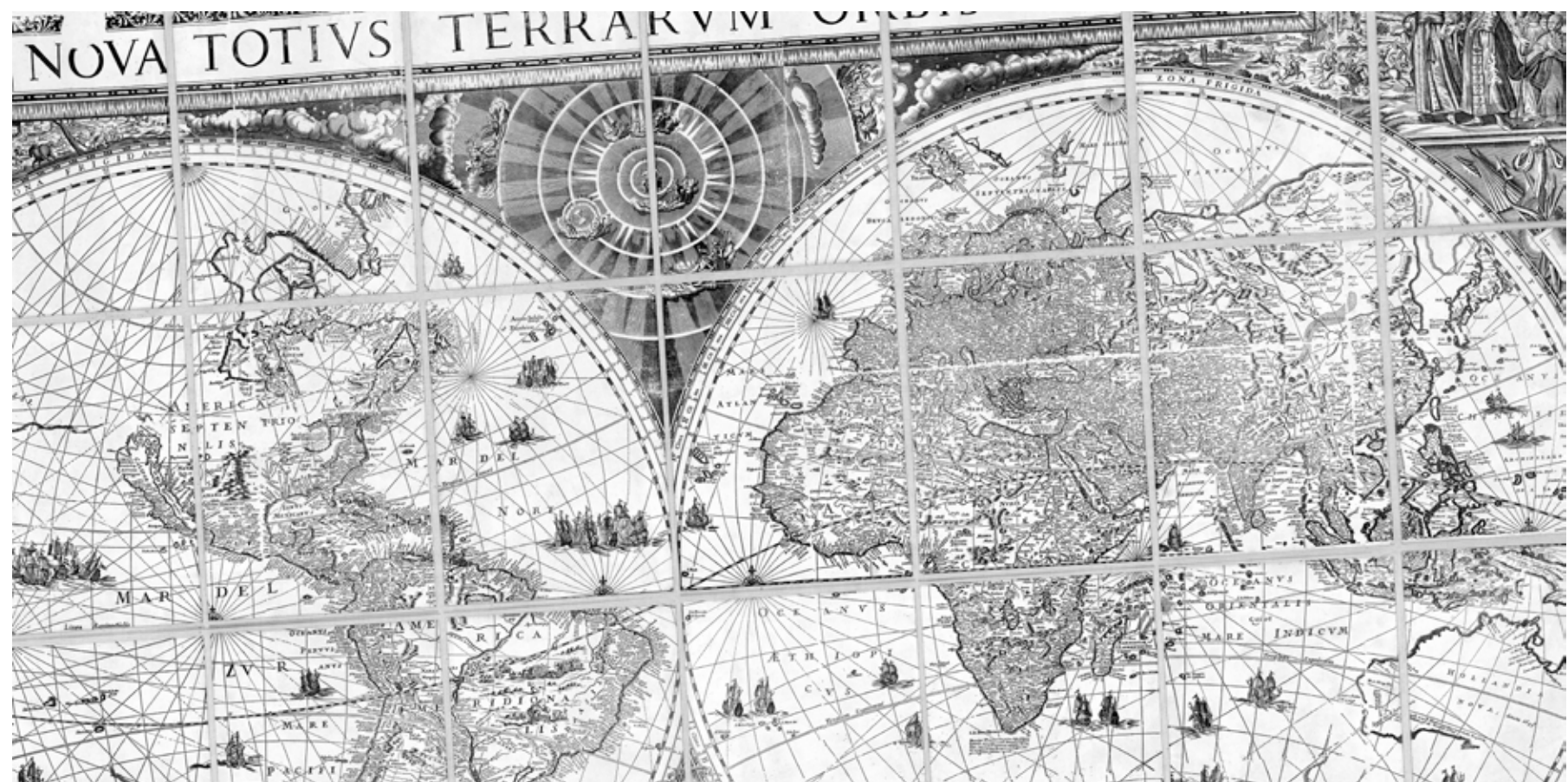

### Moduli Elite

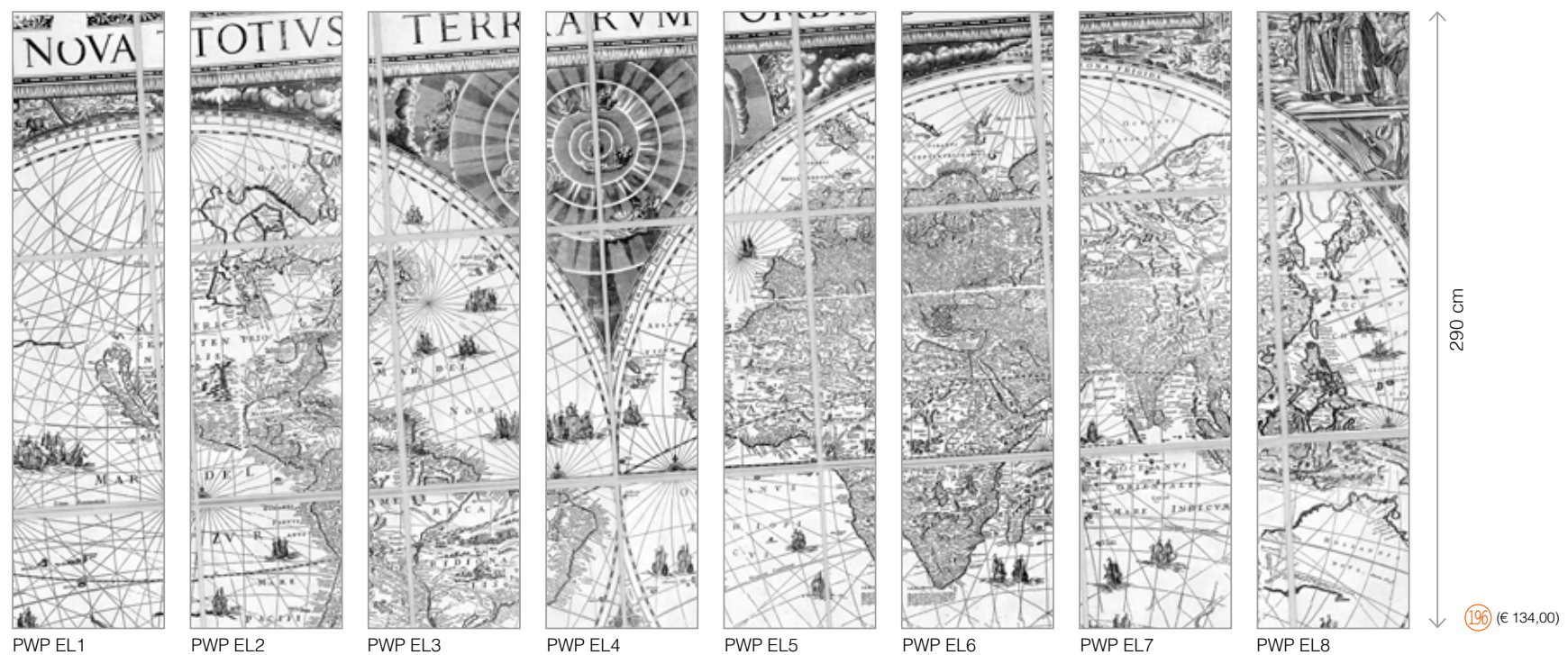

PWP EL1

PWP EL2

PWP EL3

PWP EL4

PWP EL5

PWP EL6

PWP EL7

PWP EL8





# SHADE WARM

Total size: 584x290 cm

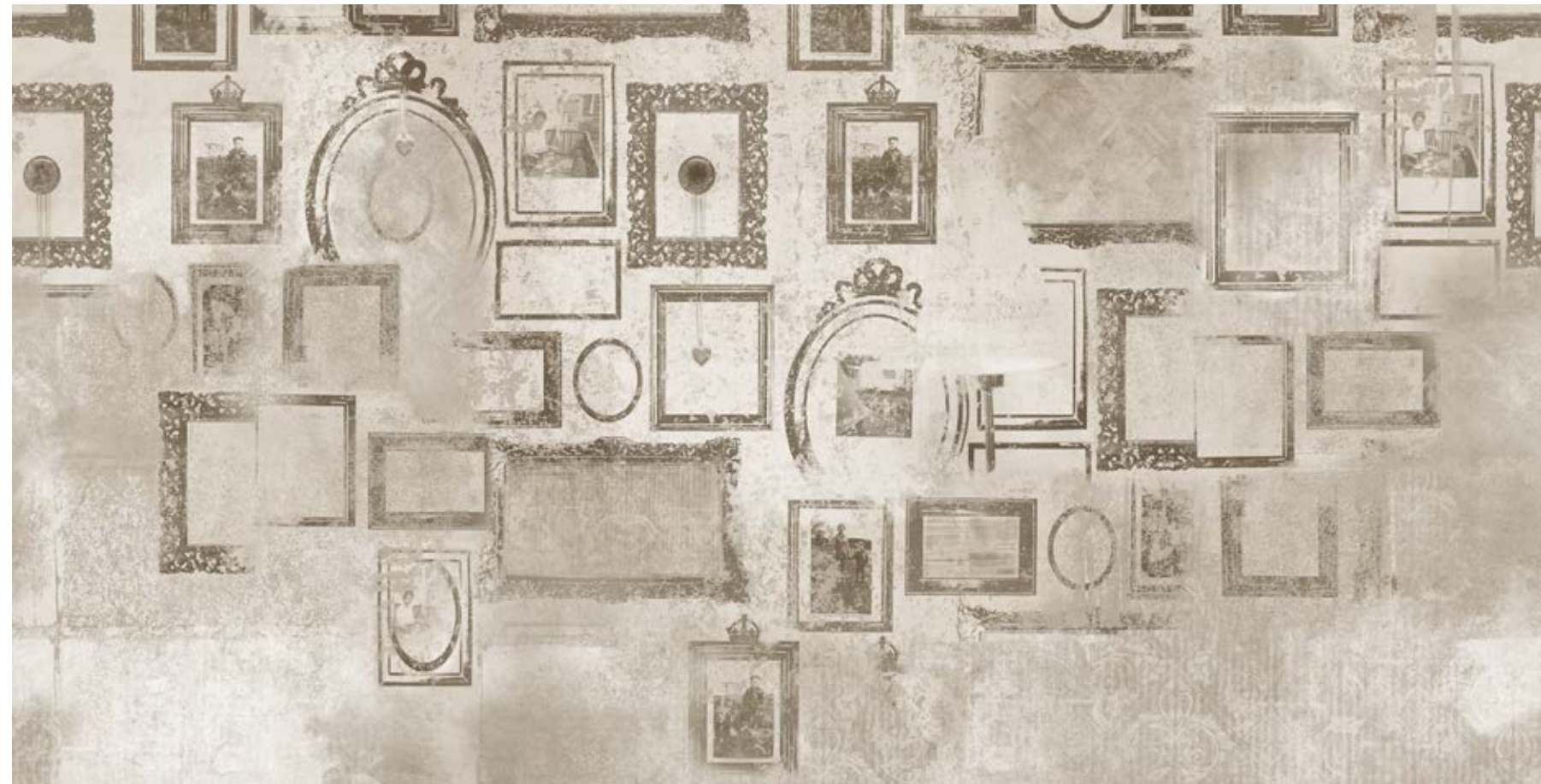

## Moduli Shade Warm

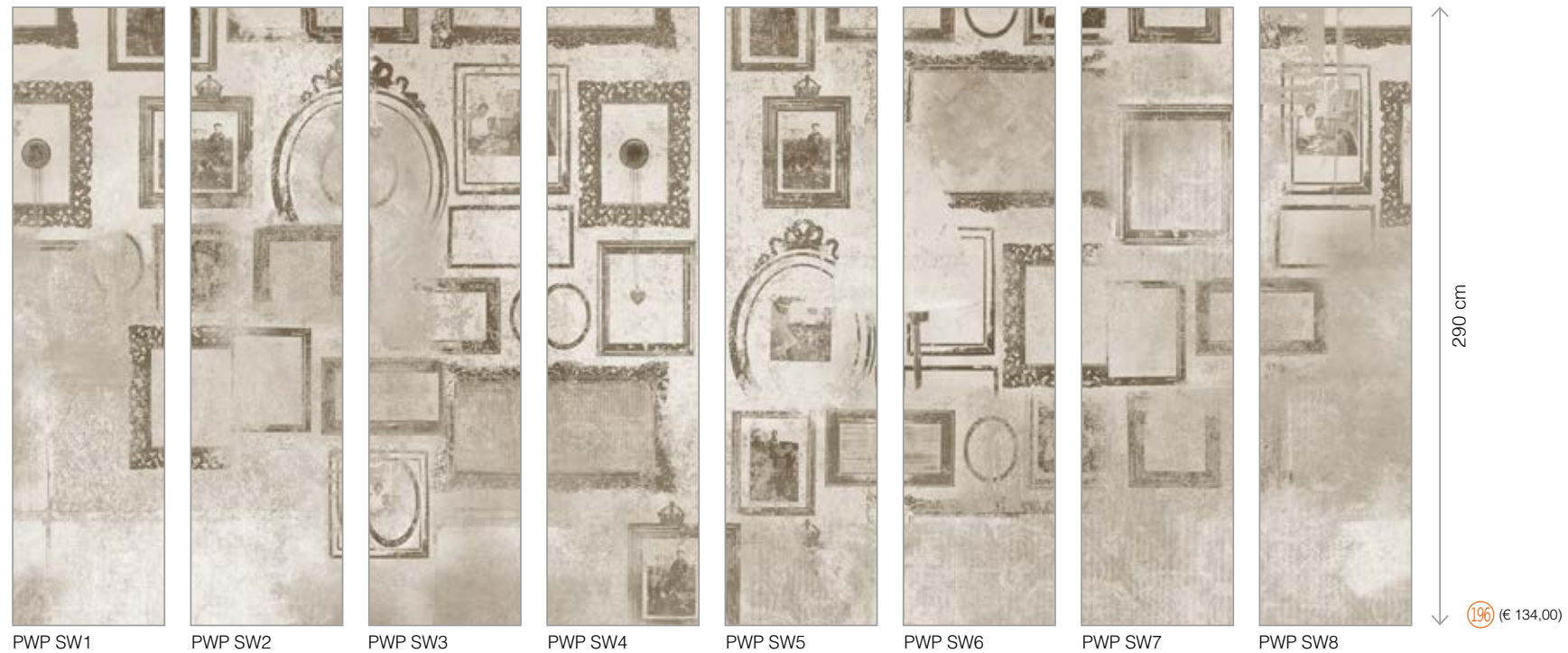

PWP SW1

PWP SW2

PWP SW3

PWP SW4

PWP SW5

PWP SW6

PWP SW7

PWP SW8



# SHADE COLD

Total size: 584x290 cm

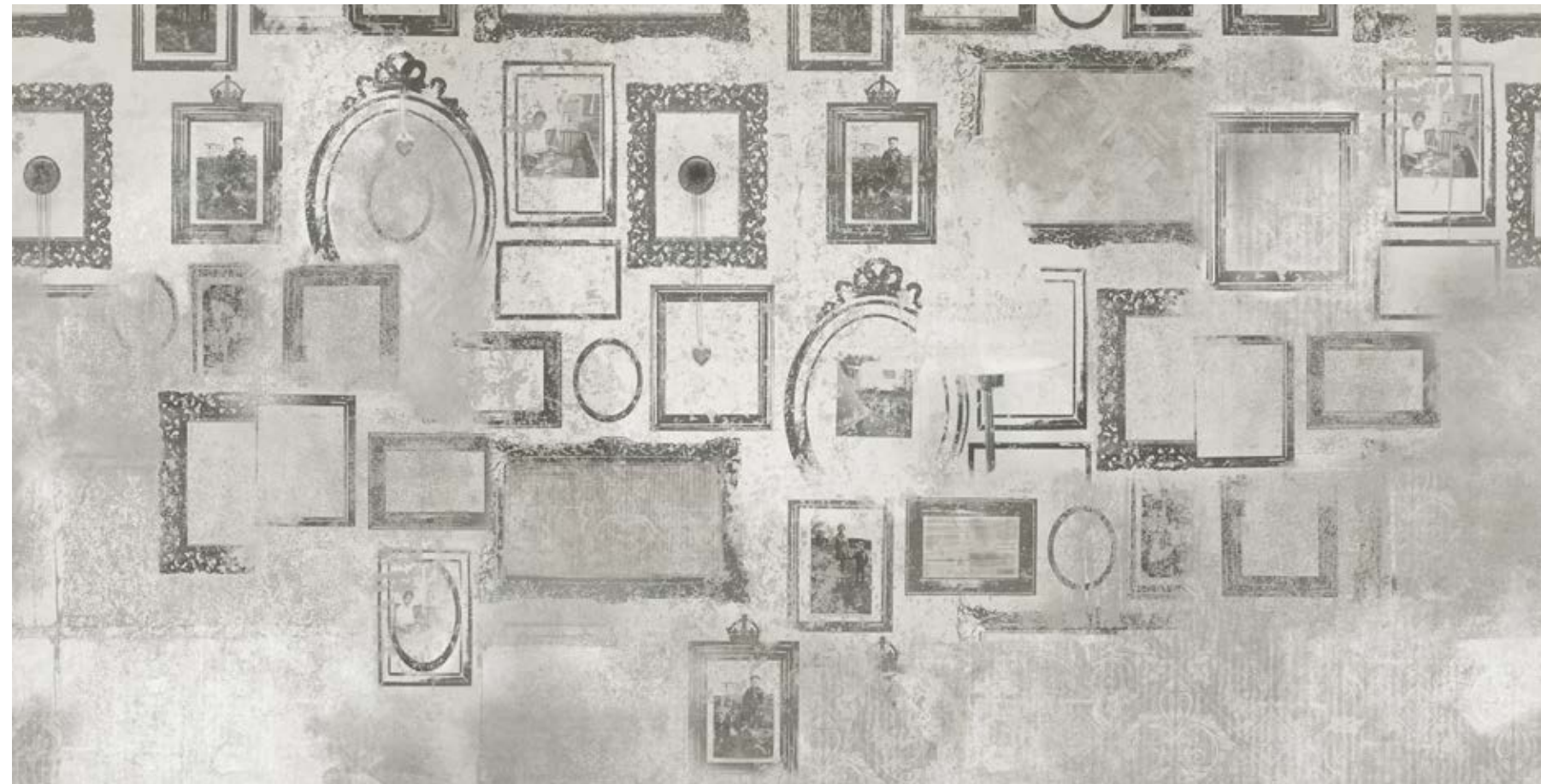

## Moduli Shade Cold

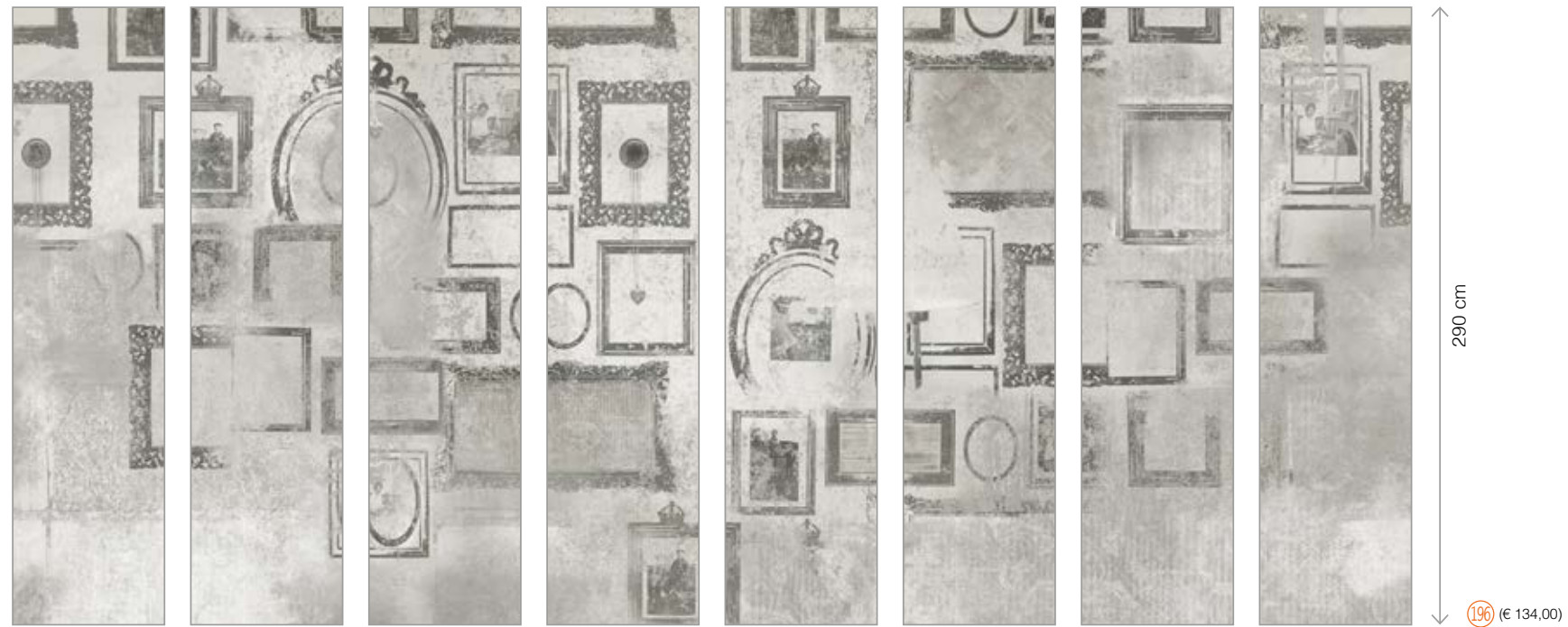

PWP SC1

PWP SC2

PWP SC3

PWP SC4

PWP SC5

PWP SC6

PWP SC7

PWP SC8



# ATELIER WARM

Total size: 584x290 cm



## Moduli Atelier Warm

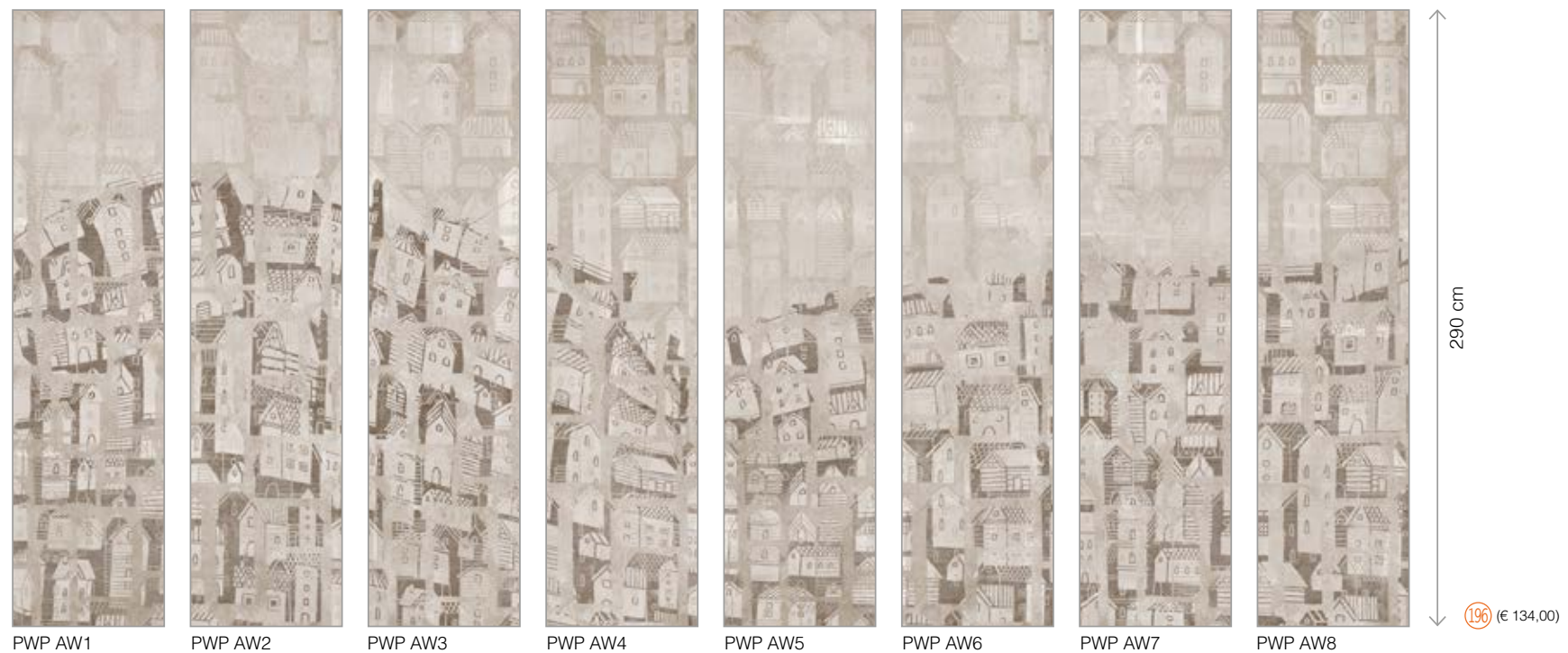

PWP AW1

PWP AW2

PWP AW3

PWP AW4

PWP AW5

PWP AW6

PWP AW7

PWP AW8



# ATELIER COLD

Total size: 584x290 cm



## Moduli Atelier Cold

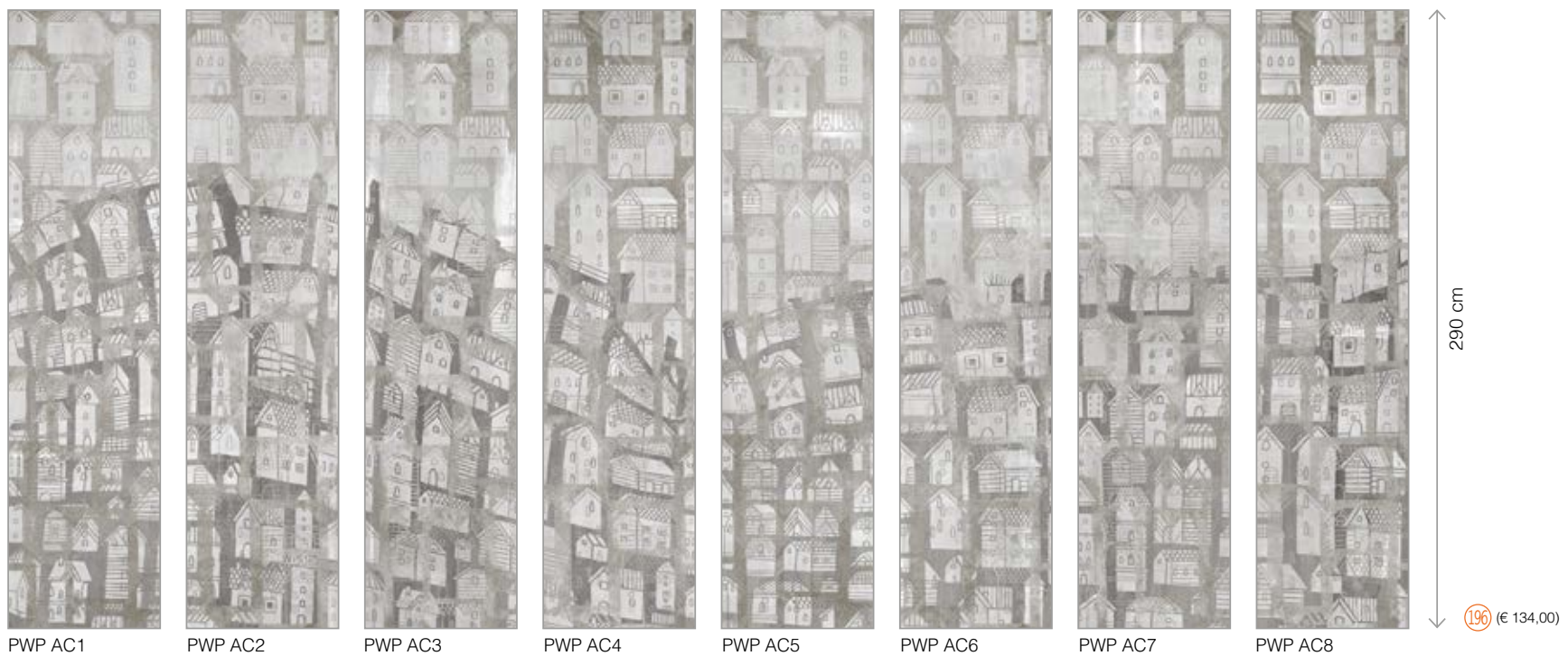

PWP AC1

PWP AC2

PWP AC3

PWP AC4

PWP AC5

PWP AC6

PWP AC7

PWP AC8



# MILANO CITY WARM

Total size: 584x290 cm



## Moduli Milano City Warm

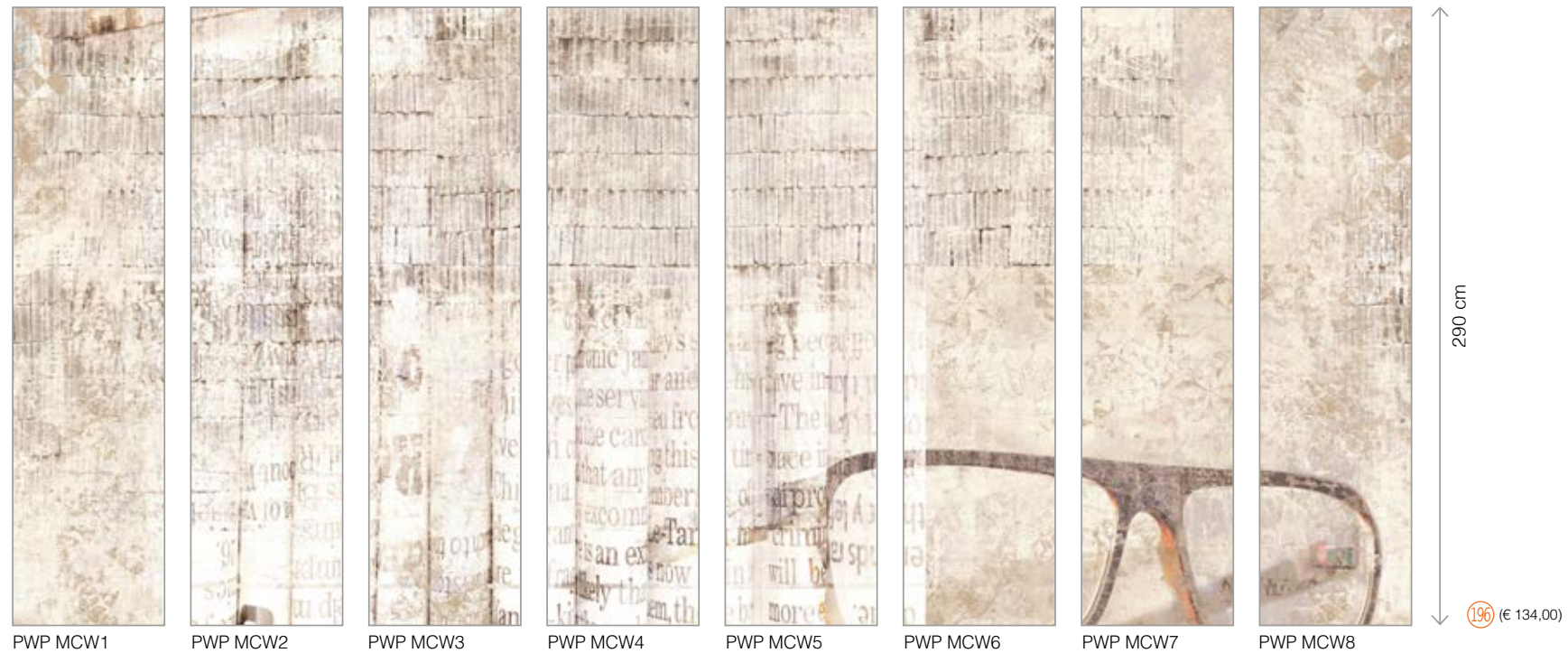

PWP MCW1

PWP MCW2

PWP MCW3

PWP MCW4

PWP MCW5

PWP MCW6

PWP MCW7

PWP MCW8



# MILANO CITY COLD

Total size: 584x290 cm

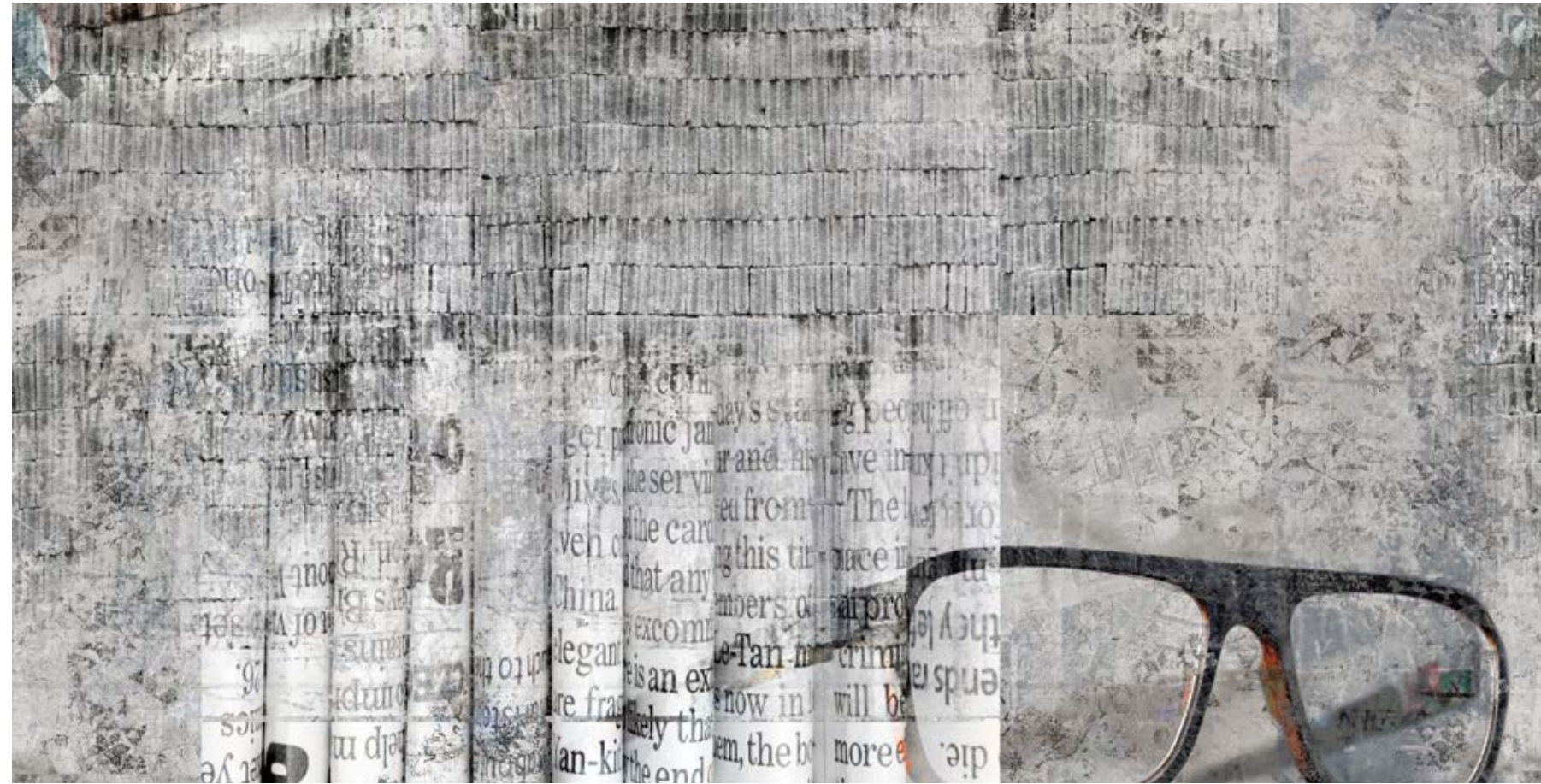

Moduli Milano City Cold

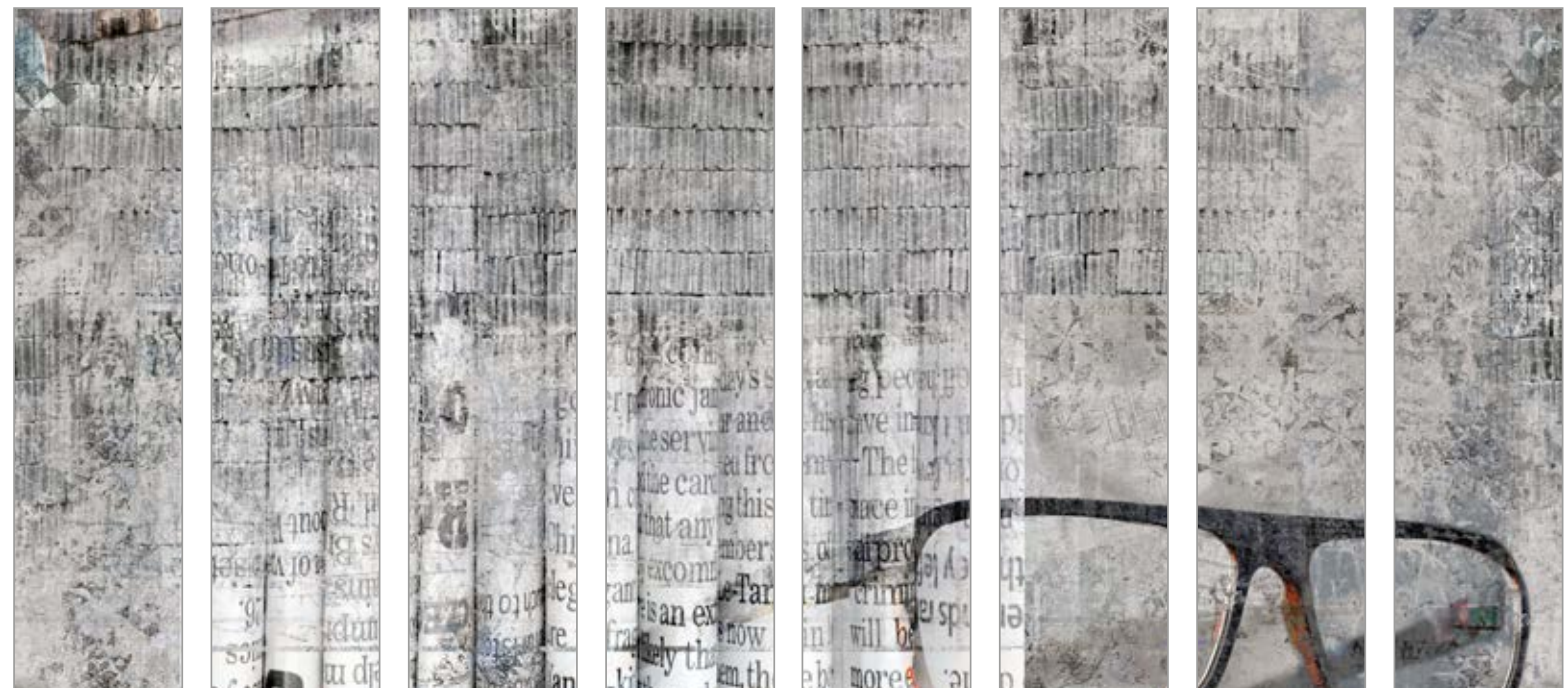

PWP MCC1 PWP MCC2 PWP MCC3 PWP MCC4 PWP MCC5 PWP MCC6 PWP MCC7 PWP MCC8

196 (€ 134,00)



# TAILORMADE

Total size: 584x290 cm



## Moduli Tailormade

<p>PWP TM1</p>	<p>PWP TM2</p>	<p>PWP TM3</p>	<p>PWP TM4</p>	<p>PWP TM5</p>	<p>PWP TM6</p>	<p>PWP TM7</p>	<p>PWP TM8</p>

73 cm

290 cm

196 (€ 134,00)

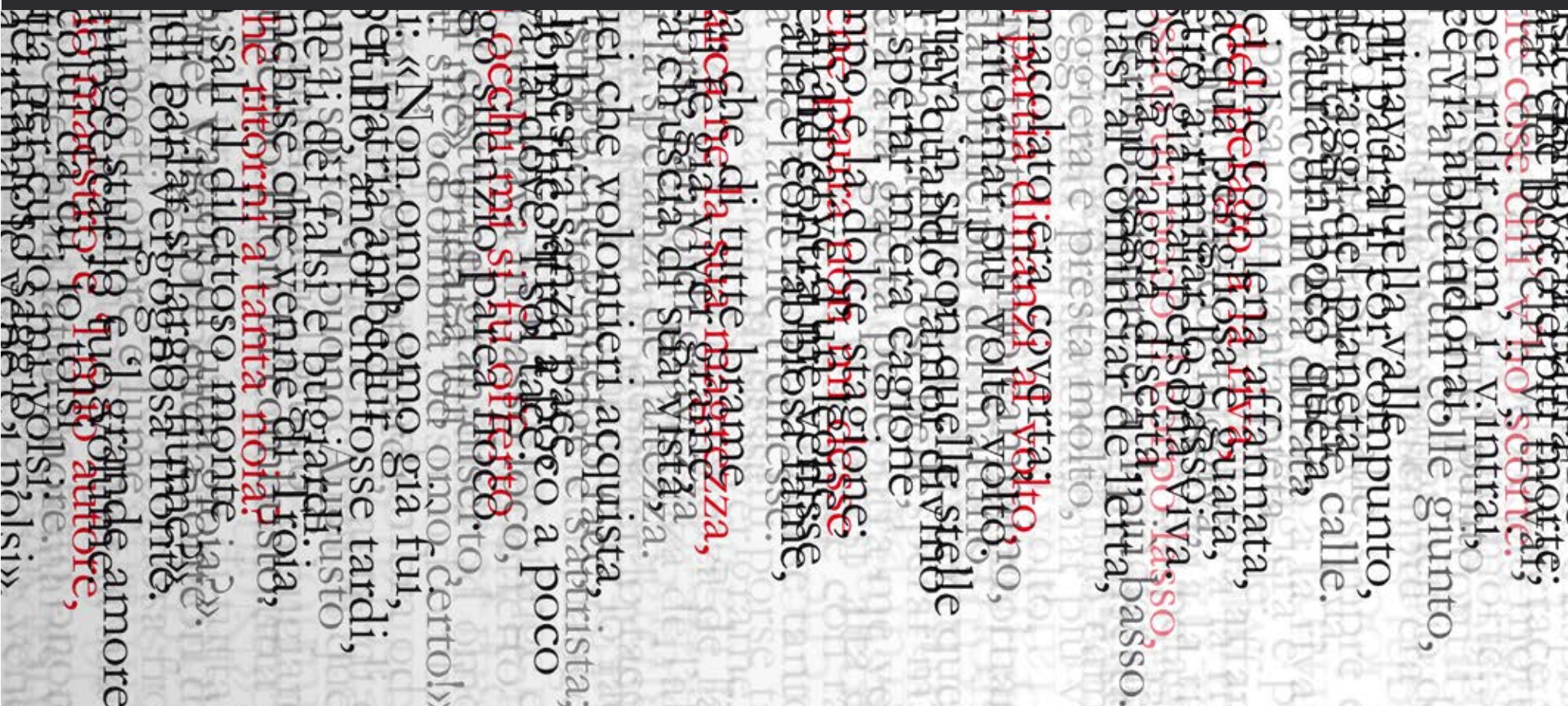

# PATINA WARM

Total size: 584x290 cm

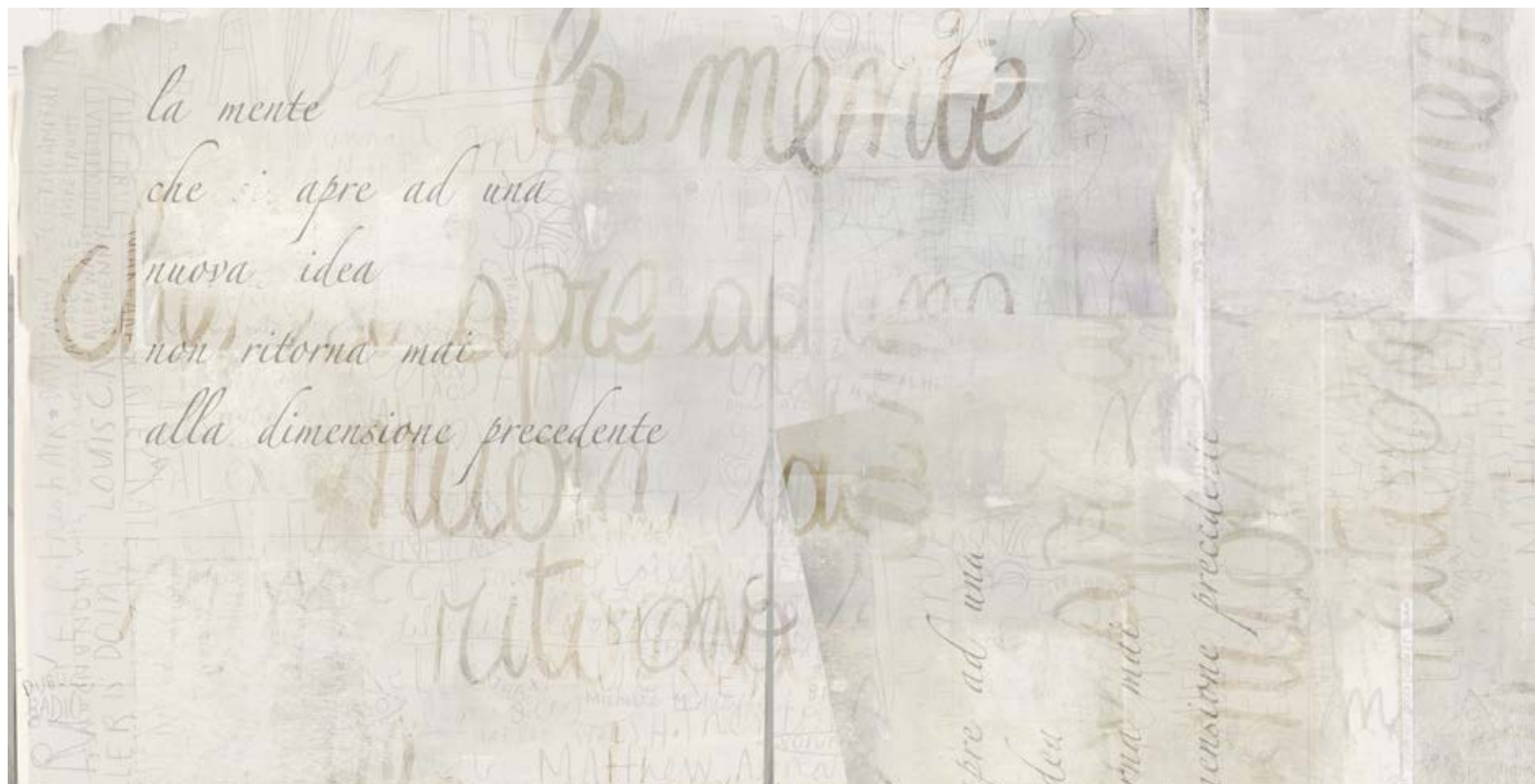

Moduli Patina Warm





# PATINA WHITE

Total size: 584x290 cm

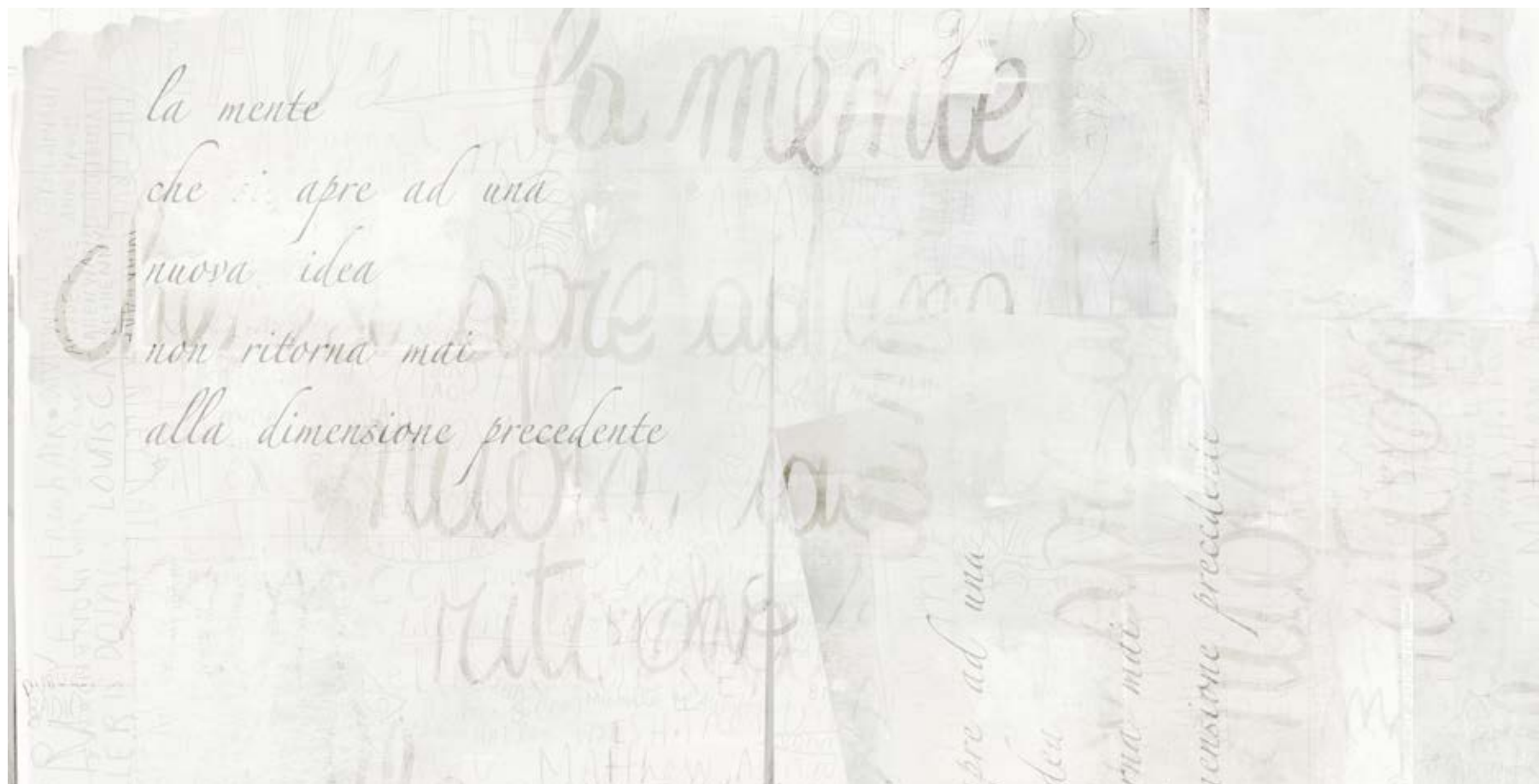

## Moduli Patina White



# MANHATTAN

Total size: 734x290 cm

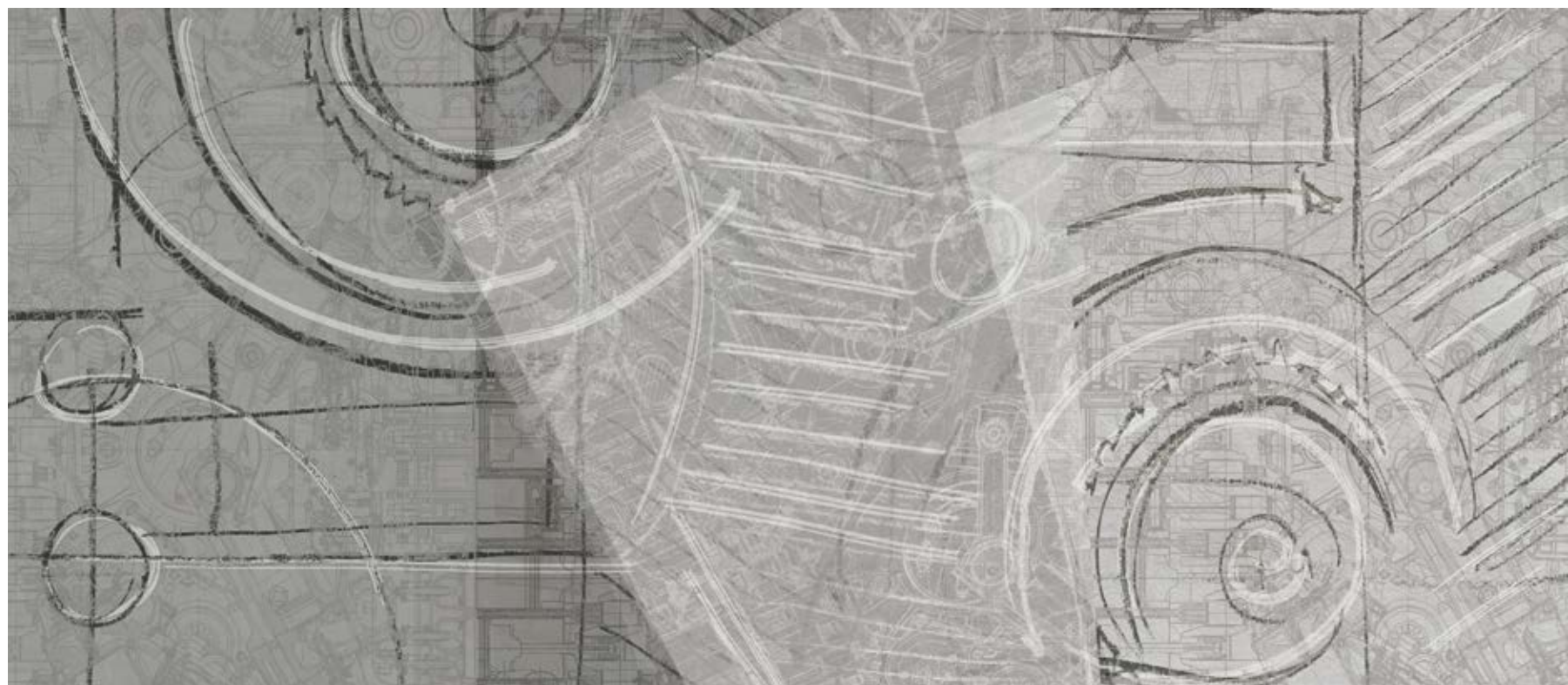

## Moduli Manhattan



PWP MA1 PWP MA2 PWP MA3 PWP MA4 PWP MA5 PWP MA6 PWP MA7 PWP MAC8 PWP MA9 PWP MA10

196 (€ 134,00)



**CARATTERISTICHE PRINCIPALI DI PASTORELLI WALLPAPER.**

- Ignifuga.
- In regola con le normative europee sulla salute e sull'ambiente.
- Facilità di montaggio e rimozione grazie al supporto di spessore consistente.
- Lavabile con acqua e prodotti a base di sapone neutro.

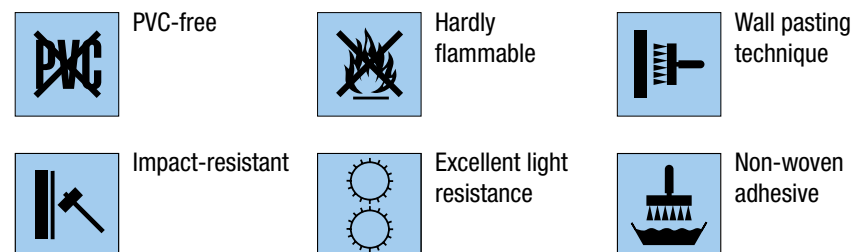
**POSA DI PASTORELLI WALLPAPER**

Per il montaggio a parete della vostra carta da parati è consigliabile affidarsi a un professionista. Tuttavia, se avete una buona manualità, è possibile procedere al fai da te.

Ecco di seguito i suggerimenti per un lavoro a regola d'arte in 6 passaggi:

- 1. Preparazione della parete.** La prima operazione da fare, una volta che avete scelto la parete dove collocare la vostra carta da parati, è ottenere una superficie completamente liscia e senza rugosità o difetti, in modo che la carta da parati aderisca in modo perfetto. Potete procedere con questa operazione raschiando la parete fino a che non sia pronta.
- 2. Preparazione della colla.** Acquistate nel vostro negozio di fiducia la colla gel adatta per la carta da parati. Procedete a versare la colla in un secchio, nella quantità di 200 g per metro quadro, e mescolate con una frusta (una di quelle adattabili al trapano) fino a che non spariscono eventuali grumi.
- 3. Applicazione della prima mano di colla.** Procedete poi a stendere in parete una mano la colla tramite un rullo. Lasciate asciugare per circa 20/30 minuti.
- 4. Stesura della carta.** Per prima cosa fate il piombo sulla parete, in modo da iniziare a posare correttamente la carta (ideale uno strumento laser che indichi perfettamente la linea con la quale iniziare). Poi, con davanti le indicazioni di posa del progetto, identificate il rotolo numero 2 e, calcolando che ogni rotolo ha una larghezza di 73 cm, posizionatelo come da figura, avendo cura di lasciare un margine di carta da rifilare successivamente nel rullo che andrà montato a sinistra, così da compensare difetti di perpendicolarità della parete. Procedete nello stesso modo con tutti gli altri rotoli, continuando a seguire le indicazioni di posa del progetto.
- 5. Applicazione della colla dopo la posa.** Una volta ultimato il posizionamento di tutti i rotoli procedete a stendere uno strato uniforme di colla gel, usando un pennello o una spatola. Applicare la colla gel senza diluirla, partendo dal primo rotolo, in modo uniforme e senza creare eccedenze di colla sulla superficie. Una volta terminata l'operazione rifilate con un cutter le eccedenze di carta da parati lungo tutto il perimetro della parete.
- 6. Applicazione protettivo finale.** Dopo circa 8 ore dalla stesura della colla gel sulla carta da parati, applicate uno strato di protettivo. Usate un pennello grande e realizzate una stesura uniforme su tutta la parete. Lasciare asciugare per circa 4 ore, quindi applicate una seconda mano di protettivo.

**MAIN TECHNICAL FEATURES OF PASTORELLI WALLPAPER.**

- Fireproof.
- In compliance with European regulations for healthcare and environmental conservation.
- Easy to hang and remove, thanks to the considerable thickness of its base.
- Washable with water and products based on mild soap.

**LAYING SCHEME OF PASTORELLI WALLPAPER**

It is advisable to ask to a professional in this field to fix the wallpaper on your surface. However, if you have a good manual skill, you can d.i.y.

Here-below you can find the suggestions to do the work in accordance with the highest professional standards, divided in 6 tips:

- 1. Preparation of the wall.** When you are choosing the surface to install the wallpaper, the first operation you have to do to obtain a complete flat surface, without any wrinkle or defect, is to make the wallpaper perfectly fit together with the wall. You can proceed with this operation, scratching out the surface until it is ready and flat.
- 2. Preparation of the glue.** You can buy the gel glue specific for wallpaper in your usual retail shop. Please proceed pouring the glue in a bucket, with a quantity of 200 gr/sqm and mesh it with a shaking tool (suitable for drill) until all the clots are completely disappeared.
- 3. First glue application.** Apply to the wall a first coat of glue using a paint roller. Leave it dry for about 20/30 minutes.
- 4. Wallpaper application.** Firstly put it in a perpendicular position on the wall, in order to begin laying the wallpaper properly (it is recommended to use a laser tool that can perfectly point out the line to begin with). Then, following the laying scheme's suggestions for the Project, identify the roller no. 2 and, calculating that each roller has an exact width of 73 cm, please position it like in picture no. 4, keeping in mind to leave a margin on the paper to be cut later on in the roller installed on the left side, to compensate the possible defects of perpendicularity on the wall. Please proceed in the same way with the other rollers, following the indications of relating laying scheme.
- 5. Glue application after the laying scheme.** Once the application of all rollers has been effected, please apply a compact coat of gel glue, using a paint brush or a spatula. Apply the glue without dilute it, starting from the first roller, in a uniform way, without creating any overflow. When this operation has been effected, trim with a cutter the extra parts of wallpaper along outer limit of the wall.
- 6. Application of final protection.** After about 8 hours from the application of the glue coat on the wallpaper, please apply also a final protection. Use a big brush and realize a compact layer on the wall. Let it dry for about 4 hours, then use a second application of final protection.

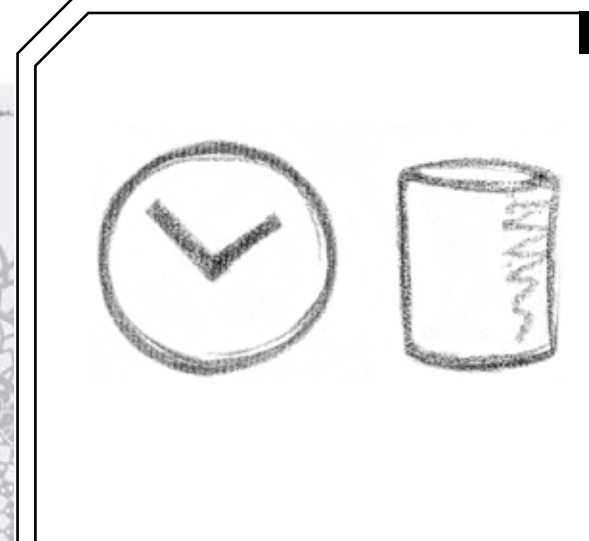
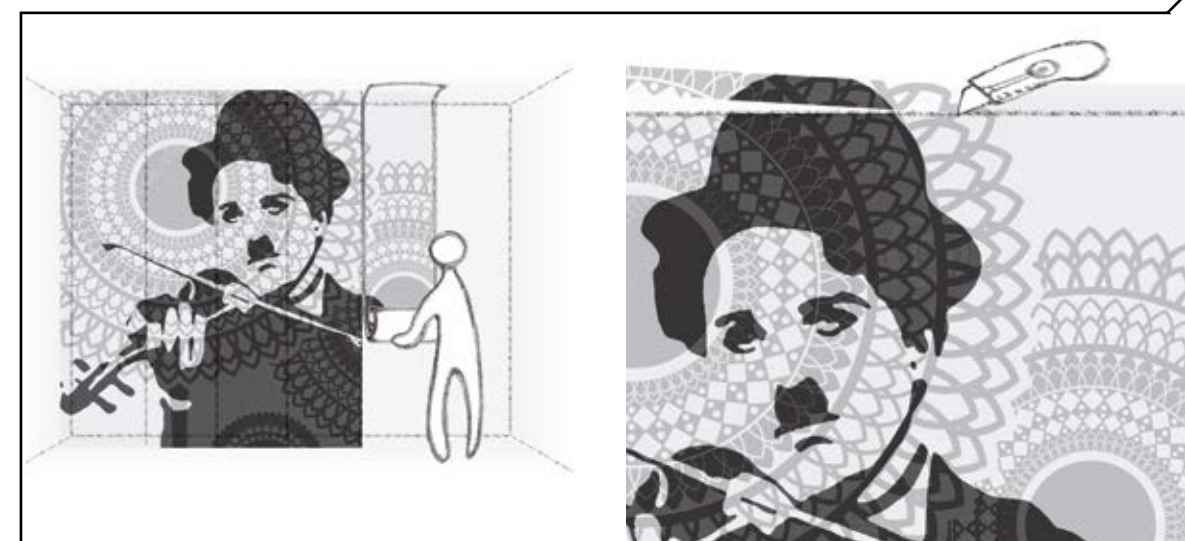
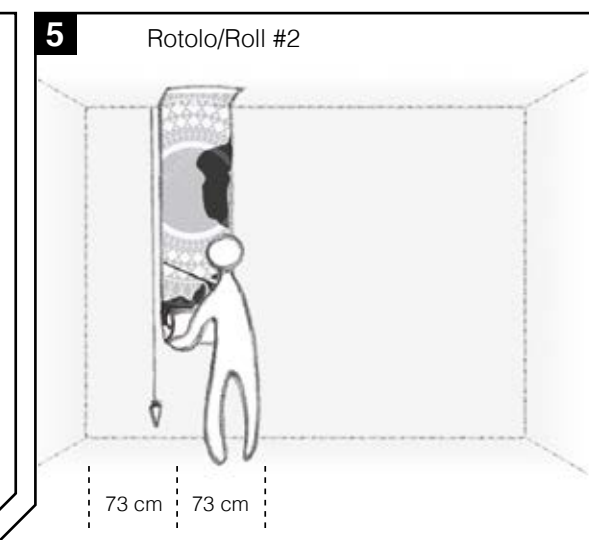
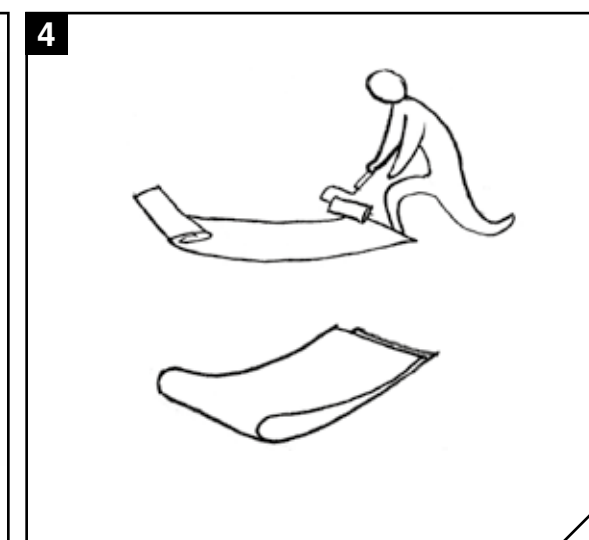
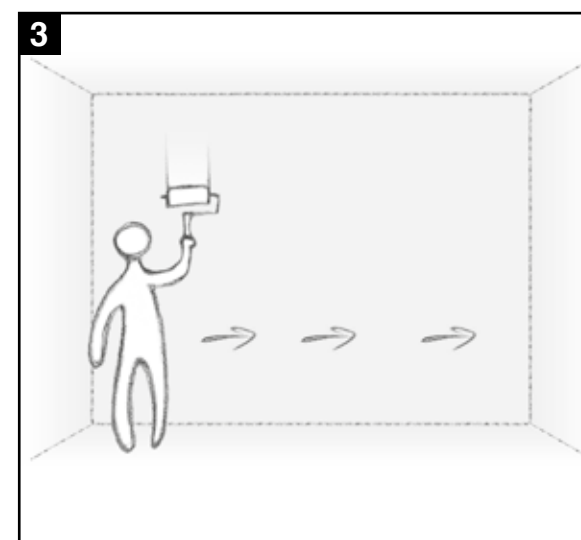
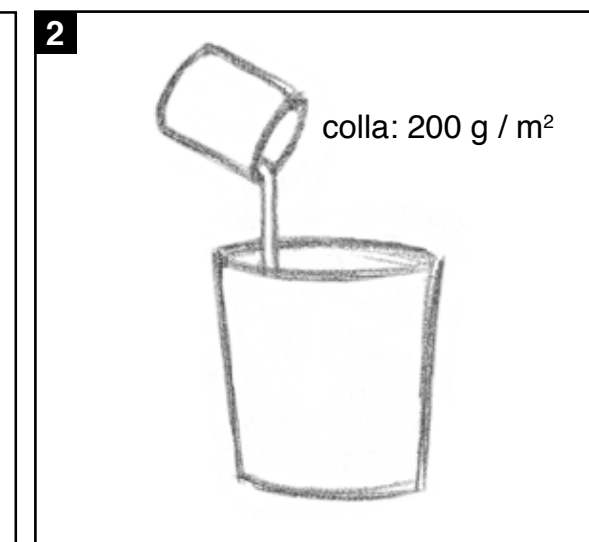
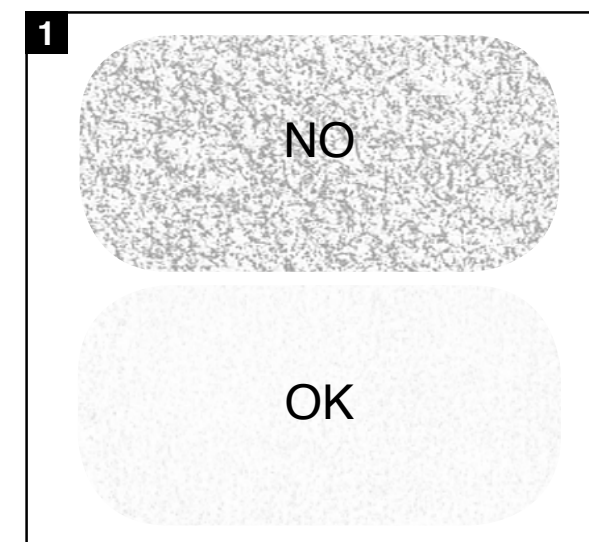

## Informazioni tecniche

---

Technical data . Renseignements techniques  
Technische Informationen . Informaciones técnicas



## La posa del Modular System

La scatola del Modular SYSTEM facilita la posa creativa e naturale di più formati. Questa confezione dà la possibilità di numerose soluzioni di posa perché è composta da più formati. Tuttavia è possibile seguire uno o più schemi fissi basati sul contenuto di ogni scatola e ripetibili su grandi superfici.

### LAYING THE MODULAR SYSTEM

The Modular SYSTEM box offers an easy solution for a creative and natural installation, combining different sizes. This packaging gives you the possibility to create several installation patterns thanks to the various sizes within the box. However, it is possible to follow one or more fixed patterns, which are based on the contents of each single box, and can be easily repeated on large surfaces.

### LA POSE DU MODULAR SYSTEM

Le kit Modular SYSTEM permet la pose créative et naturelle de plusieurs formats. Ce kit offre de nombreuses solutions de pose car il est composé par différents formats. Il est toutefois possible de suivre un ou plusieurs schémas fixes de pose, basés sur le contenu de chaque boîte, également valables pour les grandes surfaces.

### DIE VERLEGUNG DES MODULAR SYSTEM

Der Inhalt des Kartons Modular SYSTEM vereinfacht die kreative Verlegung, bietet die Möglichkeit einer kreativen und naturalen Verlegung von verschiedenen formaten. Man kann einer der auf dem Karton angegebenen Verlegungsarten wählen, die sich leicht auf grosse oberflächen uebertragen lassen.

### LA COLOCACIÓN DEL MODULAR SYSTEM

La caja del Modular SYSTEM facilita la posa creativa y natural de una pluralidad de formatos. Dicho embalaje ofrece la posibilidad de numerosas soluciones de posa en cuanto está compuesto por mas formatos. Sin embargo, es posible seguir uno o mas esquemas fijos según el contenido de cada caja y repetibles sobre grandes superficies.

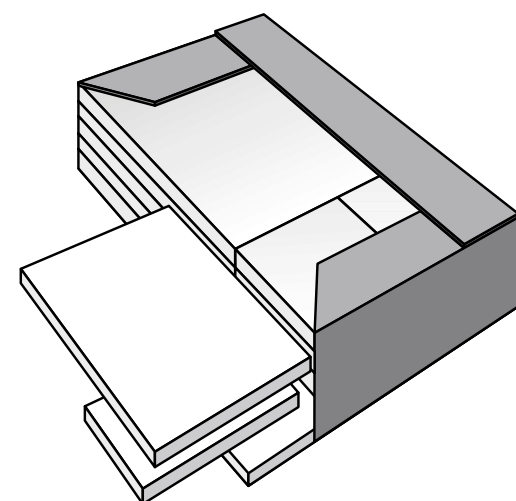

SERIE: Marmi Antichi

## Modular SYSTEM

3 Pz. 45x45  
2 Pz. 30x30  
10 Pz. 15x15

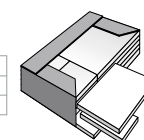

SPECIALE CONFEZIONE  
MODULARE A 15 PEZZI  
Special Modular packaging 15 pcs.  
Emballage special 15 pcs.  
Sonder Verpackung 15 stck.  
Embalaje especial modular con 15 piezas.

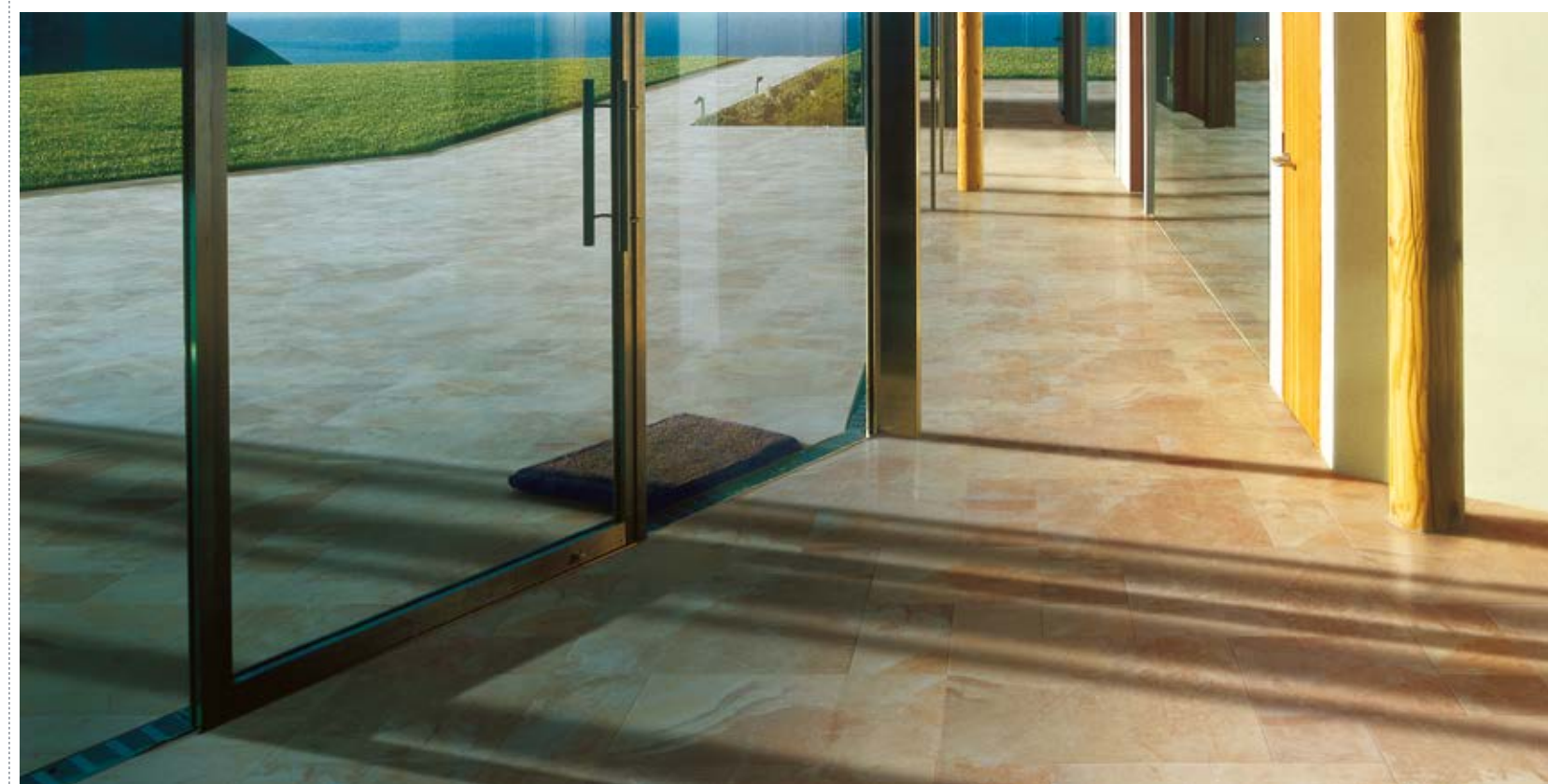
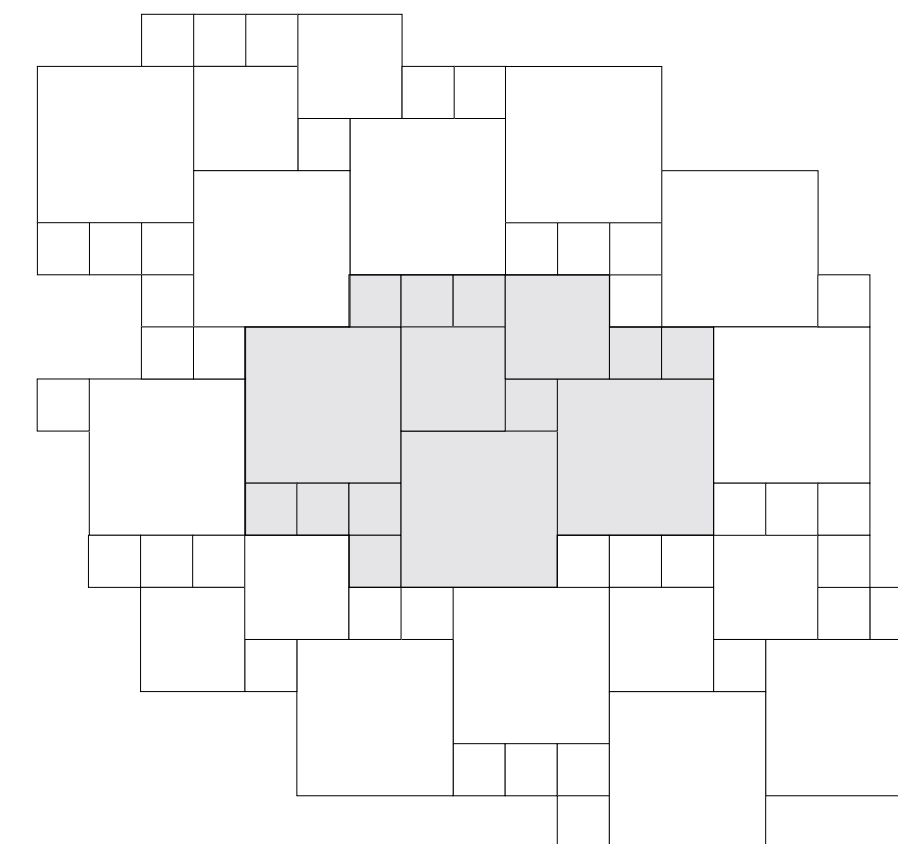

# PEZZI SPECIALI

Special trims - Pieces especiales - Sonderstücke - Piezas especiales

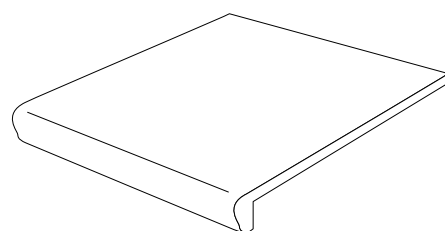

Gradone "pressato"  
SERIE: Terre Senesi

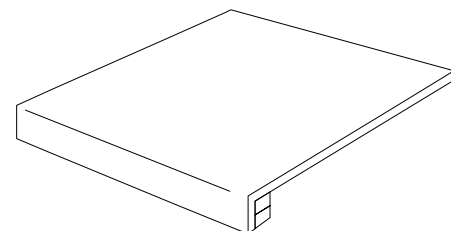

Gradone "assemblato"  
SERIE: Antiche Doghe, Himalaya, Lithos, Pierre Royale, Quarz Design, V.360, Milano City, Country Life, Elite, Madera, Shade, Atelier.

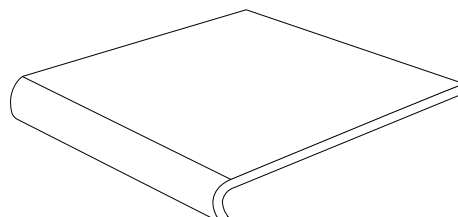

Gradone lineare  
SERIE: Tailormade

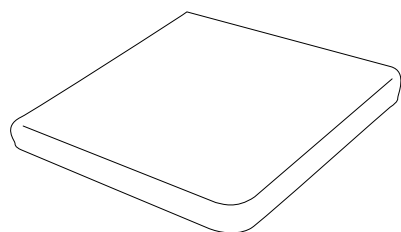

Gradone angolare "pressato"  
SERIE: Terre Senesi

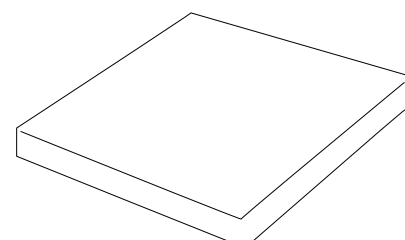

Gradone angolare "assemblato"  
SERIE: Himalaya, Lithos, Pierre Royale, Quarz Design, V.360, Milano City, Elite, Shade.

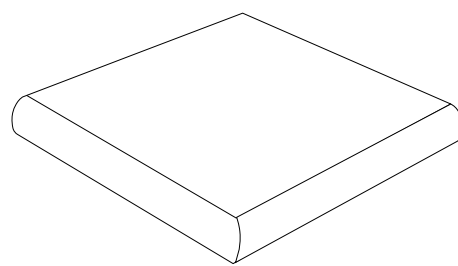

Gradone angolare  
SERIE: Tailormade

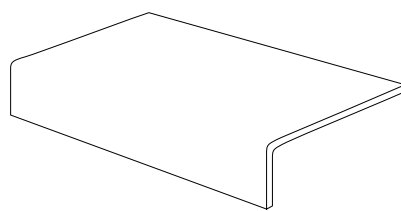

Elemento ad L monolitico "pressato"  
SERIE: Ayers Rock, Duomo

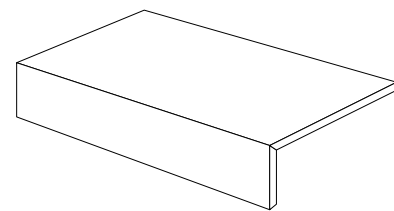

Elemento ad L "assemblato"  
SERIE: Pierre Royale

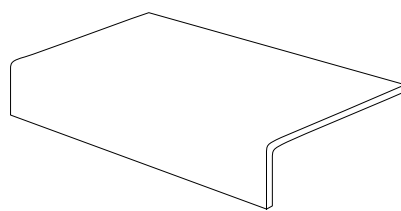

Elemento ad L "monolitico"  
SERIE: Himalaya, Quarz Design, V.360

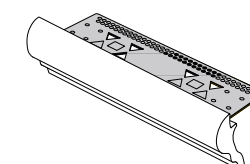

Profilo gradino  
SERIE: Duomo, Loft, Manhattan, Marfil, Villa Imperiale

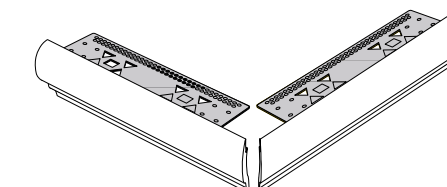

Angolo profilo gradino  
SERIE: Duomo, Loft, Manhattan, Marfil, Villa Imperiale

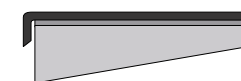

Materiali non sottoposti a sollecitazioni meccaniche (es. bordi perimetrali di balconi, di terrazze, di sommità di muretti ecc...).

Il bordo verticale non deve aderire alla malta o alla colla ma deve essere distanziato di 5-10 mm.

*Areas not subjected to mechanical stress (for example, the perimeter edges of balconies and terraces, tops of low walls etc...).*  
*The vertical edging must not adhere to the mortar. Or the adhesive, but must be clear of it by 5-10 mm.*



*Zones soumises à des pressions mécaniques (par exemple, les extrémités des balcons, terrasses murets, ect...).*  
*Le bord vertical ne doit pas être enduit de ciment ou de colle. Veiller à laisser un espace de 5-10 mm.*

*Keinen mechanischen Beanspruchungen unterliegende Materialien (z.B.: umlaufender Rand von Balkons, Terrassen, Mauerabschlüssen, usw. ....).*  
*Der senkrechte Rand darf nicht am Mörtel oder Kleber haften sondern muss einen Abstand von 5-10 mm aufweisen.*

*Materiales no sometidos a obstaculos metalicos (ej. Borde perimetrico de los balcones, terrazas, etc...).*  
*El borde vertical no se debe pegar a la argamasa o a la cola. Pero tiene que estar distanciado unos i 5-10 mm.*

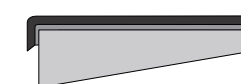

Materiali sottoposti a sollecitazioni meccaniche (es. bordi di gradini, marciapiedi, ecc...).

Nella fase di posa degli elementi piegati evitare vuoti di colla o di malta nella zona d'angolo interno.

*Areas subject to mechanical stress (for example the edges of steps, pavements etc...).*  
*During laying, avoid leaving voids in the bed of the tile.*



*Zones soumises à des pressions mécaniques (par exemple, les extrémités des marches, trottoirs, etc...).*  
*Lors de la pose, ne pas laisser d'espaces vides sous la dalle; pour la pose avec de la colle, utiliser la technique de la "double enduction".*

*Mechanischen Beanspruchungen unterliegende Materialien (z.B. Rand von Stufen, Fußwegen, usw. ...).*  
*Bei der Verlegung der gebogenen Elemente Hohlräume im Kleber oder Mörtel im Bereich des Innenwinkels vermeiden.*

*Materiales sometidos a obstaculos metalicos (ej. Bordos de peldaños, aceras, etc...).*  
*En la fase de colocacion de las piezas dobladas, se Tienen que evitar los vacios de cola o argamasa en la zora del angulo interno.*

# SCHEMI DI POSA

Laying patterns - Schémas de pose - Verlegungsschemen - Esquemas de colocación

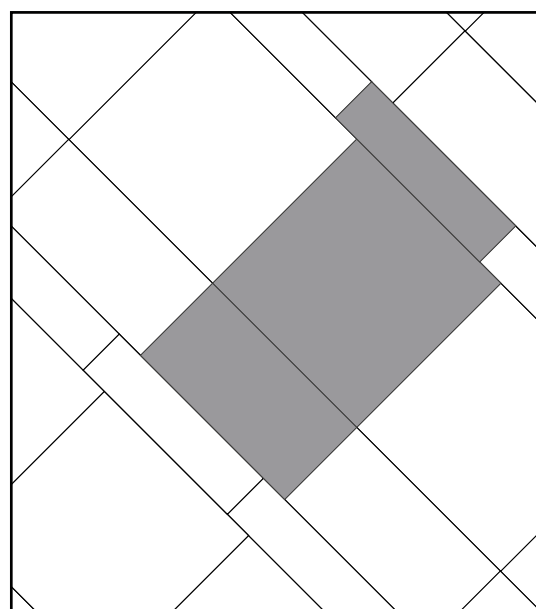

FORMATO - SIZES	%
15x60	2%
30x60	28,6%
60x60	57,1%

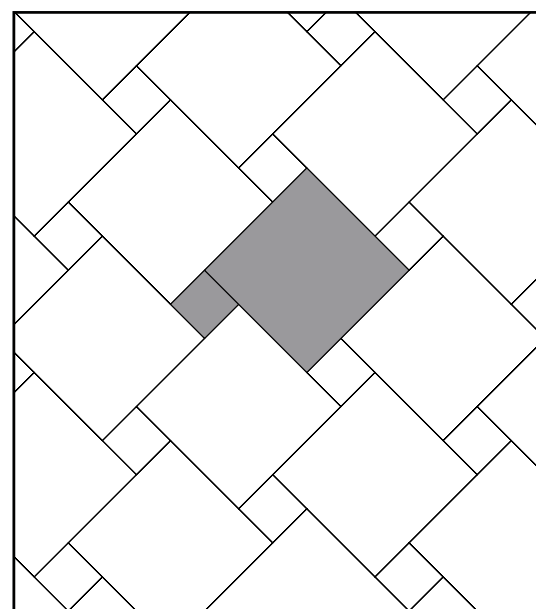

FORMATO - SIZES	%
15x15	10%
45x45	90%

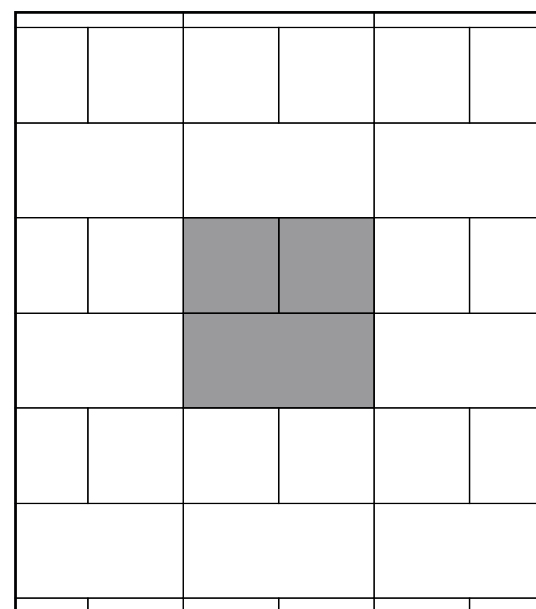

FORMATO - SIZES	%
20x20	50%
20x40	50%

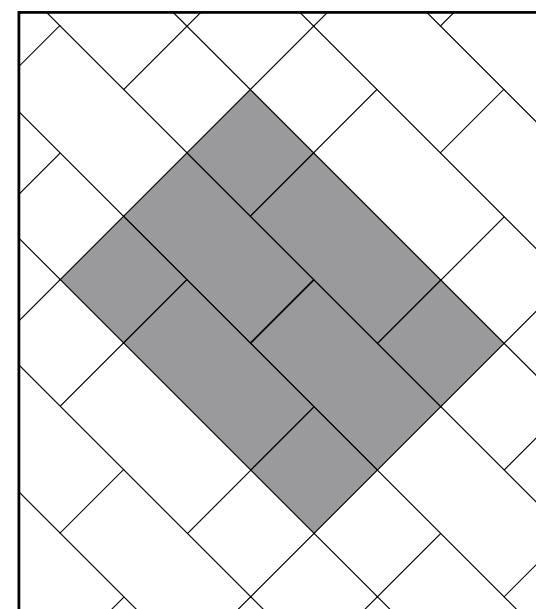

FORMATO - SIZES	%
20x20	33%
20x40	67%

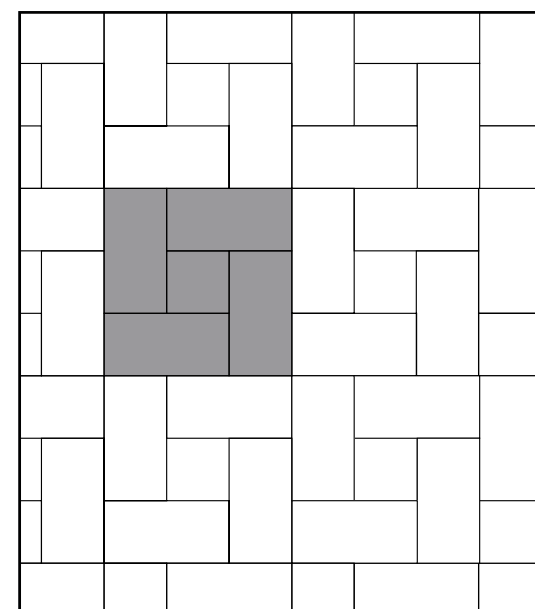

FORMATO - SIZES	%
30x30	11,1%
30x60	88,9%

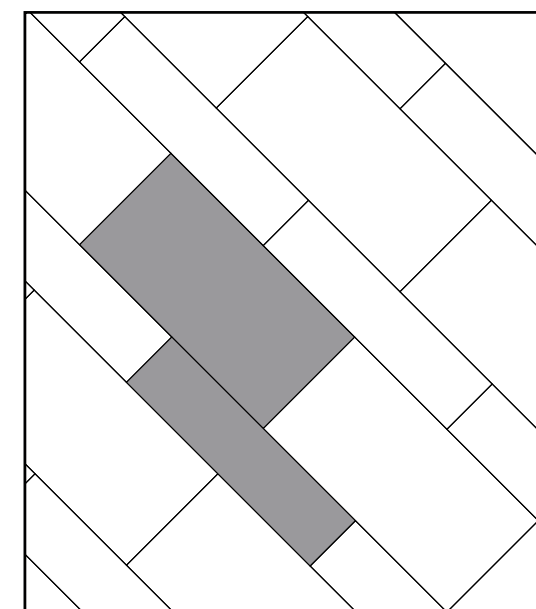

FORMATO - SIZES	%
40x80	66,6
20x80	33,4

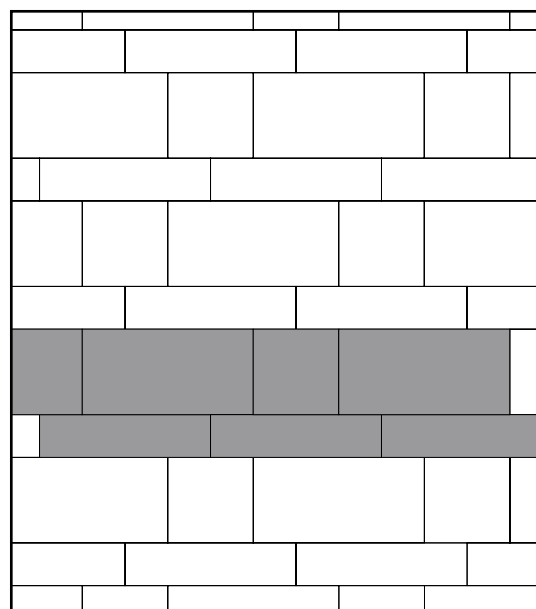

FORMATO - SIZES	%
15x60	33%
30x60	45%
30x30	22%

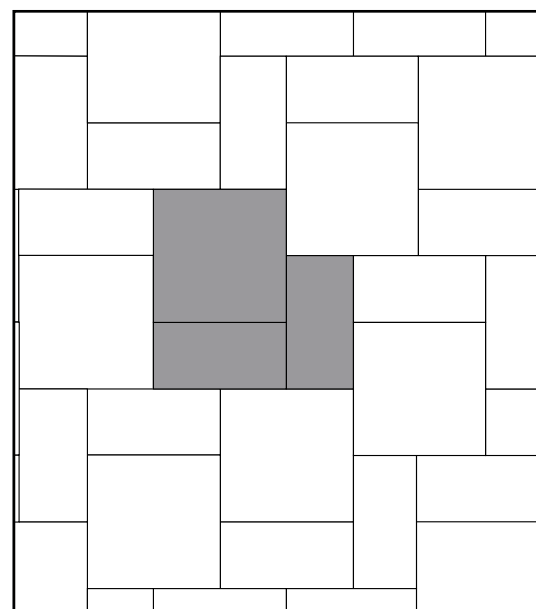

FORMATO - SIZES	%
30x60	50%
60x60	50%

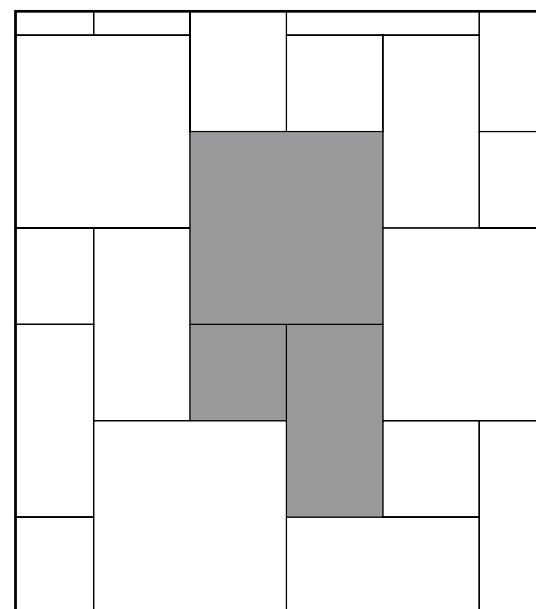

FORMATO - SIZES	%
30x30	14%
30x60	29%
60x60	57%

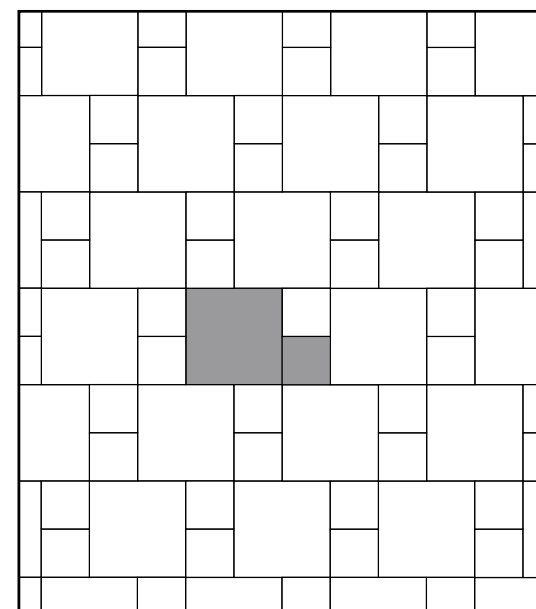

FORMATO - SIZES	%
30x30	66,6
15x15	33,4

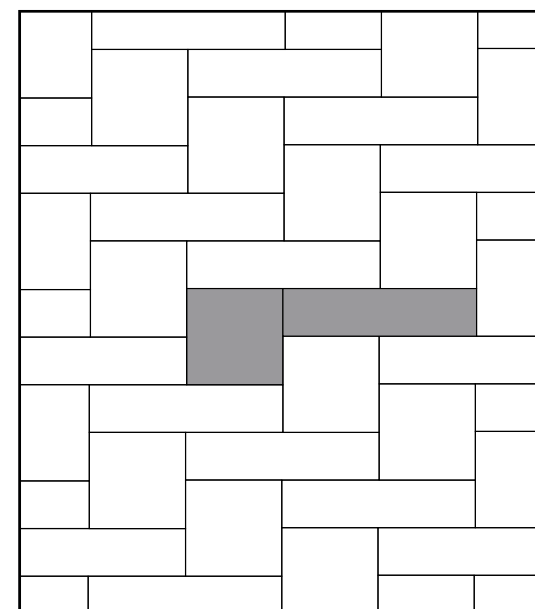

FORMATO - SIZES	%
30x30	50
15x60	50

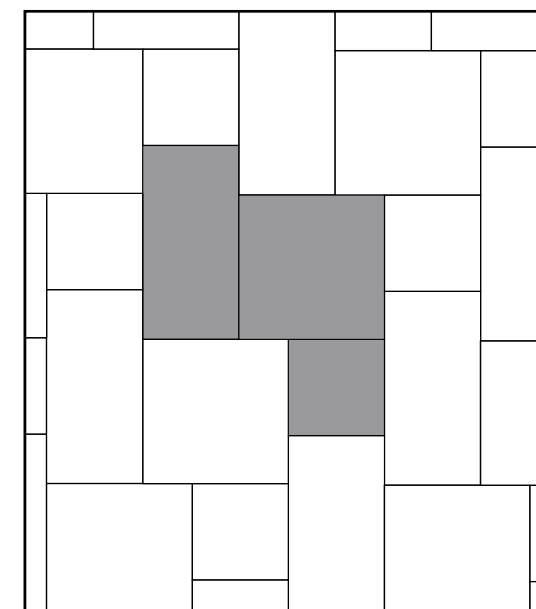

FORMATO - SIZES	%
30x30	22,2%
30x60	44,4%
45x45	33,4%

# SCHEMI DI POSA

Laying patterns - Schémas de pose - Verlegungsschemen - Esquemas de colocación

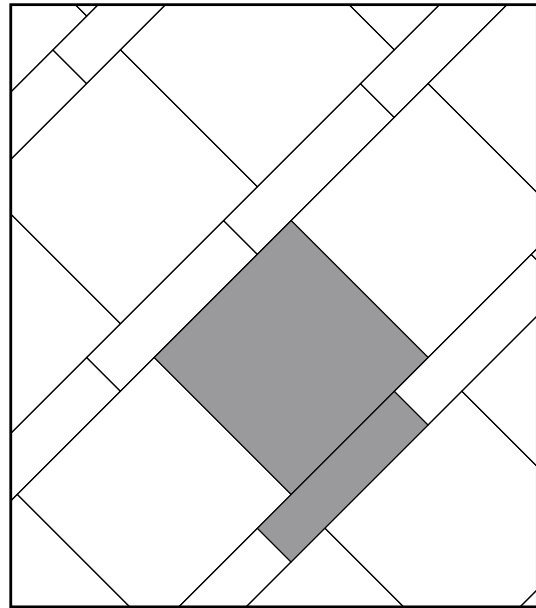

FORMATO - SIZES	%
60x60	80
15x60	20

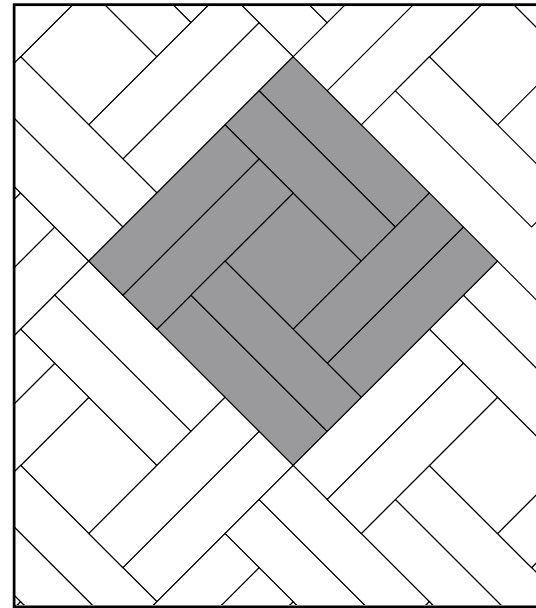

FORMATO - SIZES	%
30x30	11,1%
15x60	88,9%

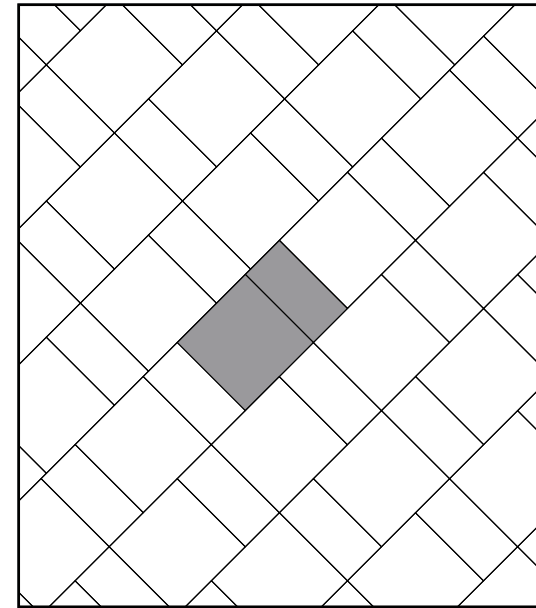

FORMATO - SIZES	%
30x30	66,6
15x30	33,4

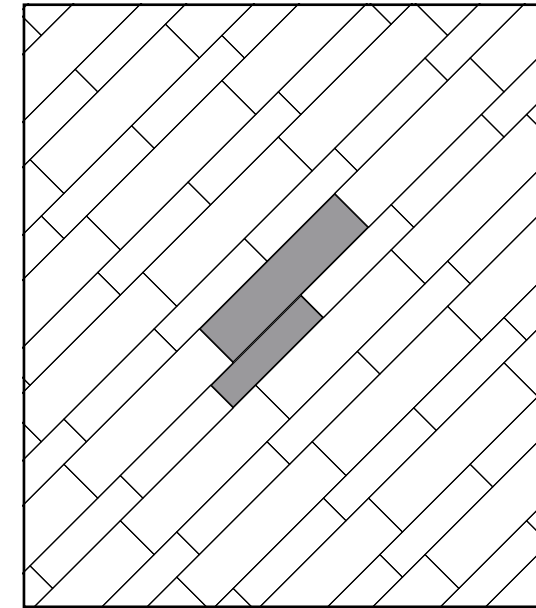

FORMATO - SIZES	%
20x80	30,77
30x120	69,23

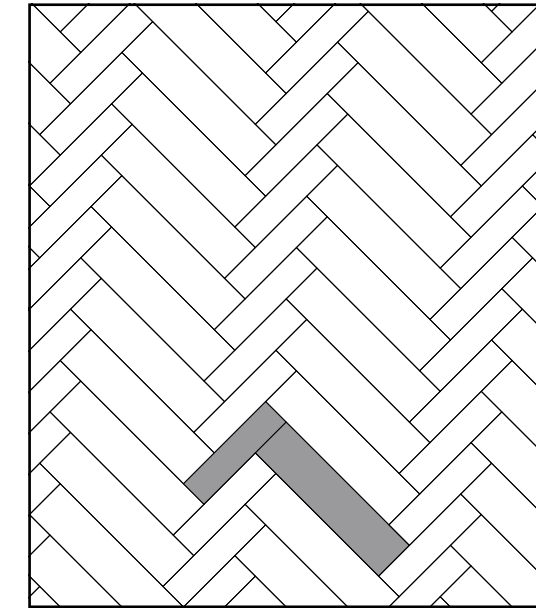

FORMATO - SIZES	%
20x80	30,77
30x120	69,23

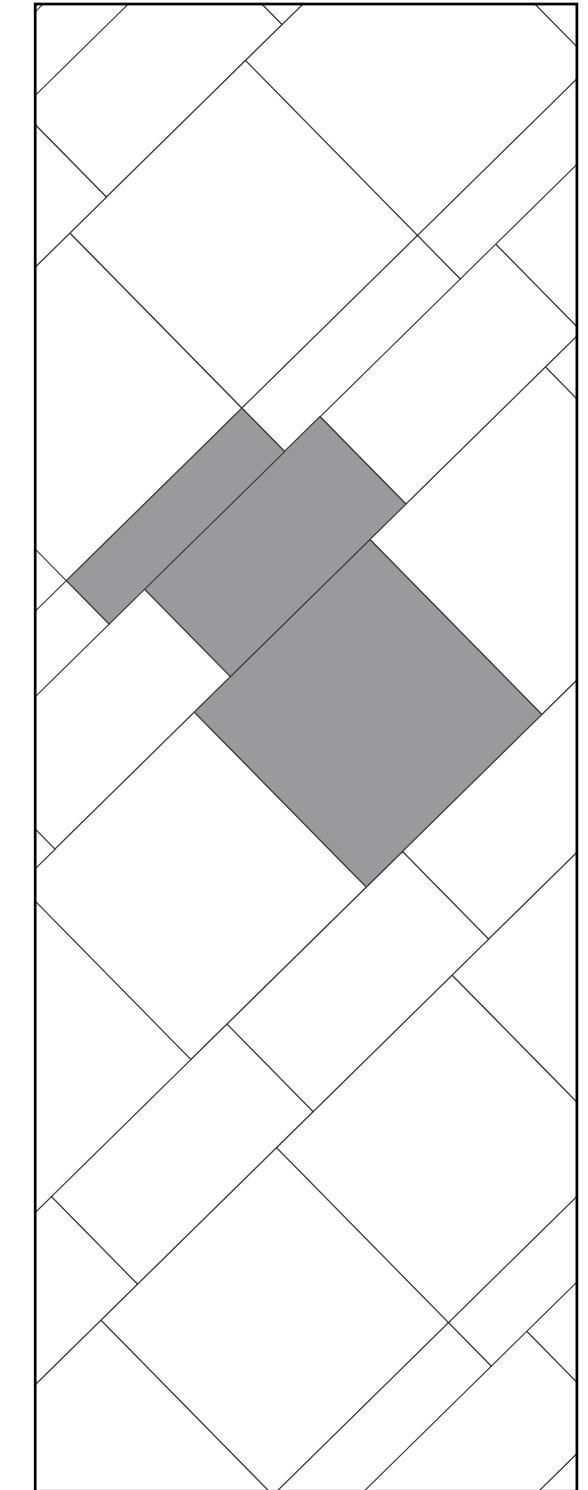

FORMATO - SIZES	%
80x80	57,14
40x80	28,57
20x80	14,28

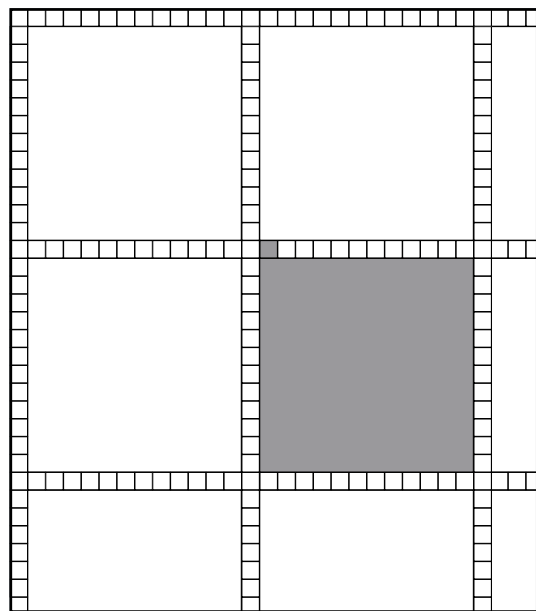

FORMATO - SIZES	%
60x60	87,70%
tozzetti 5x5	14,3%

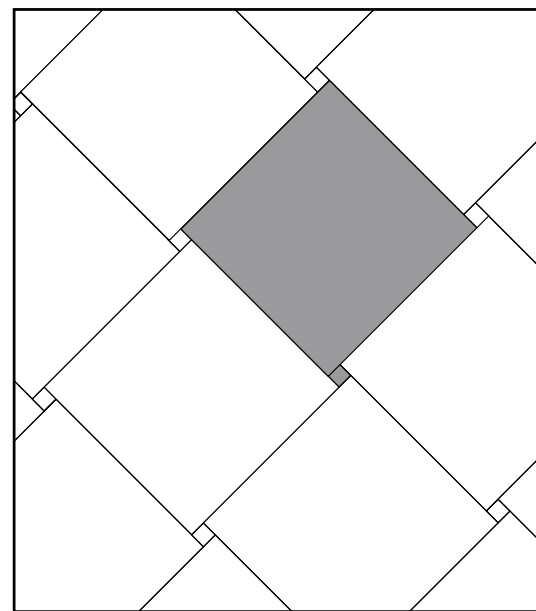

FORMATO - SIZES	%
60x60	99,3%
tozzetti 5x5	0,7%

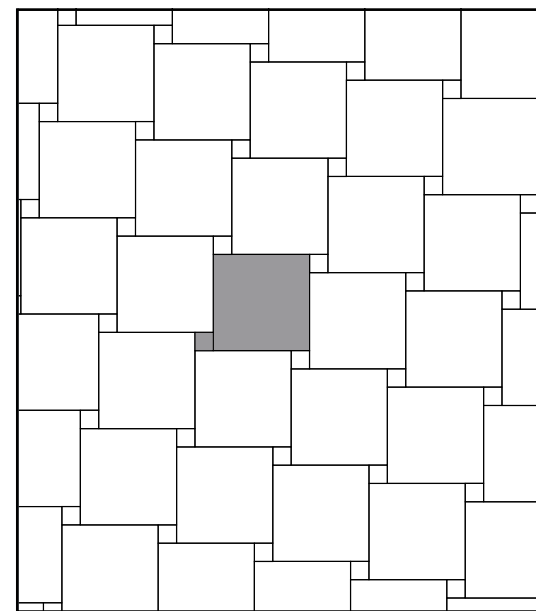

FORMATO - SIZES	%
30x30	83,3
6x6	16,7

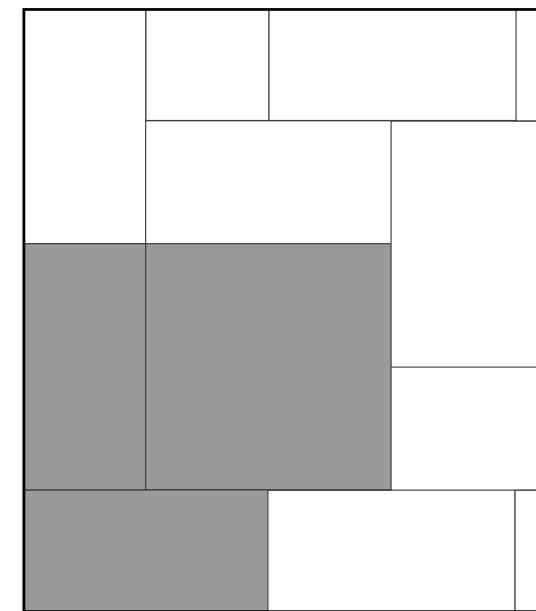



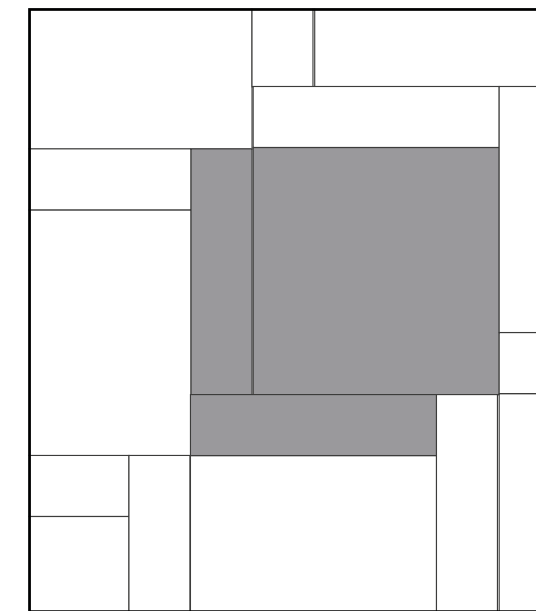











FORMATO - SIZES	%
80x80	50
40x80	50

















FORMATO - SIZES	%
80x80	66,65
20x80	33,35

















 <p><b>CARATTERISTICHE TECNICHE</b> TECHNICAL STANDARDS CHARACTERISTIQUES TECHNIQUES TECHNISCHE EINGESCHAFTEN CARACTERÍSTICAS TÉCNICAS</p>		 <p><b>UNI EN 14411 Ap. G</b></p> <p>NORME EUROPEE REFERENCE STANDARD NORME DI REFERENCE BEZUGSNORM NORMAS EUROPEAS</p>		<p>NORME ASTM REFERENCE STANDARD NORME DI REFERENCE BEZUGSNORM NORMAS</p>	 <p><b>ANSI 137.1</b></p> <p>REQUISITI REQUIREMENTS CONDITIONS REQUISES VORAUSSETZUNGEN REQUISITOS</p>	
<p>RESISTENZA AL GELO FROST RESISTANCE RESISTANCE AU GEL FROSTBESTÄNDIGKEIT RESISTENCIA AL HIELO</p>		<p>UNI EN ISO 10545-12</p>	<p>Resiste Resists Résiste Standhaltet Resiste</p>	<p>C1026</p>	<p>-</p>	<p>Resiste Resists Résiste Standhaltet Resiste</p>
<p>ASSORBIMENTO D'ACQUA WATER ABSORPTION ABSORPTION D'EAU WASSERAUFNAHME ABSORCIÓN DE AGUA</p>		<p>UNI EN ISO 10545-3</p>	<p>≤ 0,5%</p>	<p>≤ 0,1%</p>	<p>C373</p>	<p>≤ 0,5% ≤ 0,1%</p>
<p>RESISTENZA ALLA FLESSIONE BENDING STRENGTH RESISTANCE À LA FLEXION BIEGEFESTIGKEIT RESISTENCIA A LA FLEXIÓN</p>		<p>UNI EN ISO 10545-4</p>	<p>≥ 35 N/mm²</p>	<p>≥ 45 N/mm²</p>	<p>C648</p>	<p>≥ 250 Lbs ≥ 300 Lbs</p>
<p>RESISTENZA CHIMICA CHEMICAL RESISTANCE RESISTANCE CHIMIQUE CHEMIKALIENBESTÄNDIGKEIT RESISTENCIA QUÍMICA</p>		<p>UNI EN ISO 10545-13</p>	<p>Resistenza a sali da piscina o additivi ad uso domestico = Classe GB minimo <i>Resistance to swimming pool salts or additives for domestic use - class GB minimum.</i> <i>Résistance au sel de piscine ou additif domestique-classe GB minimum.</i> <i>Resistent gegen Salze in Schwimmbäder sowie im Haushaltsgebrauch = Klasse Minimum GB.</i> <i>Resistencia a las sales de piscina o a los aditivos para utilización doméstica = clase G.B. mínimo.</i></p> <p>Resistenza ad acidi e basi a bassa concentrazione = Dichiarato dal fabbricante <i>Resistance to acid and bases with low concentration - declared by the manufacturer.</i> <i>Résistance aux acides et bases à basses concentrations = Déclaré par le fabricant.</i> <i>Niedrig konzentrierte Säure und Basen beständigkeit, Herstellerklärung.</i> <i>Resistencia a los ácidos y a las bases de baja concentración = declarado por el productor.</i></p> <p>Resistenza ad acidi e basi ad alta concentrazione = Metodo di prova disponibile <i>Resistance to acids and bases with high concentration - test method available.</i> <i>Résistance aux acides et bases à hautes concentrations = méthode de preuve disponible.</i> <i>Hoch konzentrierte Säure und Basen beständigkeit, Prüfzeugnis Verfügbar.</i> <i>Resistencia a los ácidos y a las bases de alta concentración = método de prueba disponible.</i></p>	<p>Resiste Resists Résiste Standhaltet Resiste</p>	<p>C650</p>	<p>Resiste Resists Résiste Standhaltet Resiste</p>
<p>DUREZZA SUPERFICIALE (SCALA MOHS) MOHS' HARDNESS DURETÉ SUPERFICIELLE À LA RAURE RITZHÄRTE DER OBERFLÄCHE DUREZA SUPERFICIAL (ESCALA MOHS)</p>		<p>CTI - 81-7</p>	<p>≥ 5</p>	<p>CTI - 81-7</p>	<p>≥ 5</p>	<p>≥ 5</p>
<p>DILATAZIONE TERMICA LINEARE LINEAR THERMAL EXPANSION DILATATION THERMIQUE LINEAIRE LINEARE THERMISCHE AUSDEHNUNG DILATACIÓN TÉRMICA LINEAL</p>		<p>UNI EN ISO 10545-8</p>	<p>≥ 9Mk¹</p>	<p>C372</p>	<p>≥ 9Mk¹</p>	<p>≥ 9Mk¹</p>
<p>RESISTENZA AL CAVILLO RESISTANT TO CRAZING RESISTANCE À LA CRAQUELURE HAARRISSEBESTÄNDIGKEIT RESISTENCIA A LAS GRIETAS</p>		<p>UNI EN ISO 10545-11</p>	<p>Richiesta Required Demande Gefordert Solicitud</p>	<p>Resiste Resists Résiste Standhaltet Resiste</p>	<p>C424</p>	<p>Richiesta Required Demande Gefordert Solicitud</p>
<p>RESISTENZA AGLI SBALZI TERMICI RESISTANT TO THERMAL SHOCKS RÉSISTANCE AUX ÉCARTS DE TEMPÉRATURE THERMOSCHOCKBESTÄNDIGKEIT RESISTENCIA A LOS CAMBIOS BRUSCOS DE TEMPERATURA</p>		<p>UNI EN ISO 10545-9</p>	<p>-</p>	<p>Resiste Resists Résiste Standhaltet Resiste</p>	<p>C484</p>	<p>Richiesta Required Demande Gefordert Solicitud</p>
<p>RESISTENZA ALLE MACCHIE RESISTANT TO STAINING RESISTANCE AUX TACHES FLECKENBESTÄNDIGKEIT RESISTENCIA A LAS MANCHAS</p>		<p>UNI EN ISO 10545-14</p>	<p>≥ 3</p>	<p>≥ 4</p>	<p>C1378</p>	<p>≥ 3 ≥ 4</p>
<p>RESISTENZA ALL'ABRASIONE SUPERFICIALE PEI RESISTANCE TO DEEP ABRASION RESISTANCE A L'ABRASION PROFONDE WIDERSTAND GEGEN TIEFENVERSCHLEISS RESISTENCIA A LA ABRASIÓN PROFUNDA</p>		<p>UNI EN ISO 10545-7</p>	<p>Classi da 0 a 5 come dichiarato dal fabbricante <i>Classes from 0 to 5 as stated by the manufacturer.</i> <i>Classes de 0 à 5 conformément à la déclaration du fabricant.</i> <i>Klassen 0 bis 5 wie vom Hersteller angegeben.</i> <i>Clases de 0 a 5 como declarado por el fabricante.</i></p>	<p>Valore a seconda del colore prodotto. <i>Value according to pro aduct colour.</i> <i>Valeur suivant la couleur du produit.</i> <i>Wert nach der Produktfarbe.</i> <i>Valor según el color del producto.</i></p>	<p>C1027</p>	<p>Come indicato As reported. Comme indiqué ci dessus. Wie erwähnt. Como indicado.</p>















Vista l'ampia gamma di prodotti i valori sopra riportati sono la media della gamma produttiva.  
Because the selection of products is very wide, the figures given above are the average for the product range. - Etant donné la vaste gamme de produits les valeurs rapportées sont la moyenne de la gamme de production.  
Angesichts des großen Produktangebots sind die oben wiedergegebenen Werte Durchschnittswerte, die sich auf die gesamte Produktion beziehen. - Dada la amplia gama de productos, los valores anteriormente mencionados son la media de la gama productiva.

 <p>CARATTERISTICHE TECNICHE TECHNICAL STANDARDS CHARACTERISTIQUES TECHNIQUES TECHNISCHE EINGESCHAFTEN CARACTERÍSTICAS TÉCNICAS</p>		 <p><b>UNI EN 14411 Ap. G</b></p> <p>NORME EUROPEE REFERENCE STANDARD NORME DI REFERENCE BEZUGSNORM NORMAS EUROPEAS</p>		<p>NORME ASTM REFERENCE STANDARD NORME DI REFERENCE BEZUGSNORM NORMAS</p>	 <p><b>ANSI 137.1</b></p> <p>REQUISITI REQUIREMENTS CONDITIONS REQUISES VORAUSSETZUNGEN REQUISITOS</p>	
<p>RESISTENZA AL GELO FROST RESISTANCE RESISTANCE AU GEL FROSTBESTÄNDIGKEIT RESISTENCIA AL HIELO</p>		<p>UNI EN ISO 10545-12</p>	<p>Resiste Resists Résiste Standhaltet Resiste</p>	<p>C1026</p>	<p>-</p>	<p>Resiste Resists Résiste Standhaltet Resiste</p>
<p>ASSORBIMENTO D'ACQUA WATER ABSORPTION ABSORPTION D'EAU WASSERAUFNAHME ABSORCIÓN DE AGUA</p>		<p>UNI EN ISO 10545-3</p>	<p>≤ 0,5%</p>	<p>≤ 0,1%</p>	<p>C373</p>	<p>≤ 0,5% ≤ 0,1%</p>
<p>RESISTENZA ALLA FLESSIONE BENDING STRENGTH RESISTANCE À LA FLEXION BIEGEFESTIGKEIT RESISTENCIA A LA FLEXIÓN</p>		<p>UNI EN ISO 10545-4</p>	<p>≥ 35 N/mm²</p>	<p>≥ 45 N/mm²</p>	<p>C648</p>	<p>≥ 250 Lbs ≥ 300 Lbs</p>
<p>RESISTENZA CHIMICA CHEMICAL RESISTANCE RESISTANCE CHIMIQUE CHEMIKALIENBESTÄNDIGKEIT RESISTENCIA QUÍMICA</p>		<p>UNI EN ISO 10545-13</p>	<p>Resistenza a sali da piscina o additivi ad uso domestico = Classe GB minimo <i>Resistance to swimming pool salts or additives for domestic use - class GB minimum.</i> <i>Résistance au sel de piscine ou additif domestique-classe GB minimum.</i> <i>Resistent gegen Salze in Schwimmbäder sowie im Haushaltsgebrauch = Klasse Minimum GB.</i> <i>Resistencia a las sales de piscina o a los aditivos para utilización doméstica = clase G.B. mínimo.</i></p> <p>Resistenza ad acidi e basi a bassa concentrazione = Dichiarato dal fabbricante <i>Resistance to acid and bases with low concentration - declared by the manufacturer.</i> <i>Résistance aux acides et bases à basses concentrations = Déclaré par le fabricant.</i> <i>Niedrig konzentrierte Säure und Basen beständigkeit, Herstellerklärung.</i> <i>Resistencia a los ácidos y a las bases de baja concentración = declarado por el productor.</i></p> <p>Resistenza ad acidi e basi ad alta concentrazione = Metodo di prova disponibile <i>Resistance to acids and bases with high concentration - test method available.</i> <i>Résistance aux acides et bases à hautes concentrations = méthode de preuve disponible.</i> <i>Hoch konzentrierte Säure und Basen beständigkeit, Prüfzeugnis Verfügbar.</i> <i>Resistencia a los ácidos y a las bases de alta concentración = método de prueba disponible.</i></p>	<p>Resiste Resists Résiste Standhaltet Resiste</p>	<p>C650</p>	<p>Resiste Resists Résiste Standhaltet Resiste</p>
<p>DUREZZA SUPERFICIALE (SCALA MOHS) MOHS' HARDNESS DURETÉ SUPERFICIELLE À LA RAURE RITZHÄRTE DER OBERFLÄCHE DUREZA SUPERFICIAL (ESCALA MOHS)</p>		<p>CTI - 81-7</p>	<p>≥ 5</p>	<p>CTI - 81-7</p>	<p>≥ 5</p>	<p>≥ 5</p>
<p>DILATAZIONE TERMICA LINEARE LINEAR THERMAL EXPANSION DILATATION THERMIQUE LINEAIRE LINEARE THERMISCHE AUSDEHNUNG DILATACIÓN TÉRMICA LINEAL</p>		<p>UNI EN ISO 10545-8</p>	<p>≥ 9Mk¹</p>	<p>C372</p>	<p>≥ 9Mk¹</p>	<p>≥ 9Mk¹</p>
<p>RESISTENZA AL CAVILLO RESISTANT TO CRAZING RESISTANCE À LA CRAQUELURE HAARRISSEBESTÄNDIGKEIT RESISTENCIA A LAS GRIETAS</p>		<p>UNI EN ISO 10545-11</p>	<p>Richiesta Required Demande Gefordert Solicitud</p>	<p>Resiste Resists Résiste Standhaltet Resiste</p>	<p>C424</p>	<p>Richiesta Required Demande Gefordert Solicitud</p>
<p>RESISTENZA AGLI SBALZI TERMICI RESISTANT TO THERMAL SHOCKS RÉSISTANCE AUX ÉCARTS DE TEMPÉRATURE THERMOSCHOCKBESTÄNDIGKEIT RESISTENCIA A LOS CAMBIOS BRUSCOS DE TEMPERATURA</p>		<p>UNI EN ISO 10545-9</p>	<p>-</p>	<p>Resiste Resists Résiste Standhaltet Resiste</p>	<p>C484</p>	<p>Richiesta Required Demande Gefordert Solicitud</p>
<p>RESISTENZA ALLE MACCHIE RESISTANT TO STAINING RESISTANCE AUX TACHES FLECKENBESTÄNDIGKEIT RESISTENCIA A LAS MANCHAS</p>		<p>UNI EN ISO 10545-14</p>	<p>≥ 3</p>	<p>≥ 4</p>	<p>C1378</p>	<p>≥ 3 ≥ 4</p>
<p>RESISTENZA ALL'ABRASIONE SUPERFICIALE PEI RESISTANCE TO DEEP ABRASION RESISTANCE A L'ABRASION PROFONDE WIDERSTAND GEGEN TIEFENVERSCHLEISS RESISTENCIA A LA ABRASIÓN PROFUNDA</p>		<p>UNI EN ISO 10545-7</p>	<p>Classi da 0 a 5 come dichiarato dal fabbricante <i>Classes from 0 to 5 as stated by the manufacturer.</i> <i>Classes de 0 à 5 conformément à la déclaration du fabricant.</i> <i>Klassen 0 bis 5 wie vom Hersteller angegeben.</i> <i>Clases de 0 a 5 como declarado por el fabricante.</i></p>	<p>Valore a seconda del colore prodotto. <i>Value according to pro aduct colour.</i> <i>Valeur suivant la couleur du produit.</i> <i>Wert nach der Produktfarbe.</i> <i>Valor según el color del producto.</i></p>	<p>C1027</p>	<p>Come indicato As reported. Comme indiqué ci dessus. Wie erwähnt. Como indicado.</p>

Vista l'ampia gamma di prodotti i valori sopra riportati sono la media della gamma produttiva.  
Because the selection of products is very wide, the figures given above are the average for the product range. - Etant donné la vaste gamme de produits les valeurs rapportées sont la moyenne de la gamme de production.  
Angesichts des großen Produktangebots sind die oben wiedergegebenen Werte Durchschnittswerte, die sich auf die gesamte Produktion beziehen. - Dada la amplia gama de productos, los valores anteriormente mencionados son la media de la gama productiva.

 <p>CARATTERISTICHE TECNICHE TECHNICAL STANDARDS CHARACTERISTIQUES TECHNIQUES TECHNISCHE EINGESCHAFTEN CARACTERÍSTICAS TÉCNICAS</p>	<p>NORME EUROPEE REFERENCE STANDARD NORME DI RIFERENZA BEZUGSNORM NORMAS EUROPEAS</p>	 <p><b>UNI EN 14411 Ap. G</b></p> <p>REQUISITI REQUIREMENTS CONDITIONS REQUISES VORAUSSETZUNGEN REQUISITOS</p>		<p>NORME ASTM REFERENCE STANDARD NORME DI RIFERENZA BEZUGSNORM NORMAS</p>	 <p><b>ANSI 137.1</b></p> <p>REQUISITI REQUIREMENTS CONDITIONS REQUISES VORAUSSETZUNGEN REQUISITOS</p>	
RESISTENZA AL GELO <i>FROST RESISTANCE RESISTANCE AU GEL FROSTBESTÄNDIGKEIT RESISTENCIA AL HIELO</i>		UNI EN ISO 10545-12	-	C1026	-	Resiste Resists Résiste Standhallet Resiste
ASSORBIMENTO D'ACQUA <i>WATER ABSORPTION ABSORPTION D'EAU WASSERAUFNAHME ABSORCIÓN DE AGUA</i>		UNI EN ISO 10545-3	≤ 0,5%	C373	≤ 0,5%	≤ 0,1%
RESISTENZA ALLA FLESSIONE <i>BENDING STRENGTH RESISTANCE À LA FLEXION BIEGEFESTIGKEIT RESISTENCIA A LA FLEXIÓN</i>		UNI EN ISO 10545-4	≥ 35 N/mm <sup>2</sup>	C648	≥ 250 Lbs	≥ 300 Lbs
RESISTENZA CHIMICA <i>CHEMICAL RESISTANCE RESISTANCE CHIMIQUE CHEMIKALBESTÄNDIGKEIT RESISTENCIA QUÍMICA</i>		UNI EN ISO 10545-13	Resistenza a sali da piscina o additivi ad uso domestico = Classe GB minimo <i>Resistance to swimming pool salts or additives for domestic use – class GB minimum. Résistance au sel de piscine ou additif domestique – classe GB minimum. Resistent gegen Salze im Schwimmbäder sowie im Haushaltgebrauch = Klasse Minimum GB. Resistencia a los sales de piscina o a los aditivos para utilización doméstica = clase G.B. mínimo.</i>	Resiste Resists Résiste Standhallet Resiste	-	Resiste Resists Résiste Standhallet Resiste
			Resistenza ad acidi e basi a bassa concentrazione = Dichiarato dal fabbricante <i>Resistance to acid and bases with low concentration – declared by the manufacturer. Résistance aux acides et bases à basses concentration = Déclaration du fabricant. Niedrig konzentrierte Säure und Basen beständigkei. Herstellerklärung. Resistencia a los ácidos y a las bases de baja concentración = declarado por el productor</i>	-	C650	-
			Resistenza ad acidi e basi ad alta concentrazione = Metodo di prova disponibile <i>Resistance to acids and bases with high concentration – test method available. Résistance aux acides et bases à hautes concentration=methodes de preuve disponible. Hoch konzentrierte Säure und Basen beständigkei. Prüfverfahren Verfügbar. Resistencia a los ácidos y a las bases de alta concentración = método de prueba disponible</i>	-	-	-
DUREZZA SUPERFICIALE (SCALA MOHS) <i>MOHS' HARDNESS DURETÉ SUPERFICIELLE À LA RAYURE RITZHÄRTE DER OBERFLÄCHE DUREZA SUPERFICIAL (ESCALA MOHS)</i>		CTI - 81-7	-	CTI - 81-7	-	≥ 6
RESISTENZA ALL'ABRASIONE PROFONDA <i>RESISTANCE TO DEEP ABRASION RESISTANCE A L'ABRASION PROFONDE WIDERSTAND GEGEN TIEFENVERSCHLEISS RESISTENCIA A LA ABRASIÓN PROFUNDA</i>		UNI EN ISO 10545-6	≤ 175 mm <sup>3</sup>	C1243	< 175 mm <sup>3</sup>	< 150 mm <sup>3</sup>
RESISTENZA ALLE MACCHIE <i>RESISTANT TO STAINING RESISTANCE AUX TACHES FLECKENBESTÄNDIGKEIT RESISTENCIA A LAS MANCHAS</i>		UNI EN ISO 10545-14	-	C1378	-	-
DILATAZIONE TERMICA LINEARE <i>LINEAR THERMAL EXPANSION DILATATION THERMIQUE LINEAIRE LINEARE THERMISCHE AUSDEHNUNG DILATACIÓN TÉRMICA LINEAL</i>		UNI EN ISO 10545-8	-	C372	-	-
RESISTENZA AGLI SBALZI TERMICI <i>RESISTANT TO THERMAL SHOCKS RESISTANCE AUX ÉCARTS DE TEMPÉRATURE THERMOSCHOCKBESTÄNDIGKEIT RESISTENCIA A LOS CAMBIOS BRUSCOS DE TEMPERATURA</i>		UNI EN ISO 10545-9	-	C484	Richiesta Required Demande Gefordert Solicitud	Resiste Resists Résiste Standhallet Resiste

**Vista l'ampia gamma di prodotti i valori sopra riportati sono la media della gamma produttiva**  
Because the selection of products is very wide, the figures given above are the average for the product range - Etant donné la vaste gamme de produits les valeurs rapportées sont la moyenne de la gamme de production.  
Angesichts des großen Produktangebots sind die oben wiedergegebenen Werte Durchschnittswerte, die sich auf die gesamte Produktion beziehen - Dada la amplia gama de productos, los valores anteriormente mencionados son la media de la gama productiva.

 <p>CARATTERISTICHE TECNICHE TECHNICAL STANDARDS CHARACTERISTIQUES TECHNIQUES TECHNISCHE EINGESCHAFTEN CARACTERÍSTICAS TÉCNICAS</p>	<p>NORME EUROPEE REFERENCE STANDARD NORME DI RIFERENZA BEZUGSNORM NORMAS EUROPEAS</p>	 <p><b>UNI EN 14411 Ap. K</b> Gruppo B III</p> <p>REQUISITI REQUIREMENTS CONDITIONS REQUISES VORAUSSETZUNGEN REQUISITOS</p>		<p>NORME ASTM REFERENCE STANDARD NORME DI RIFERENZA BEZUGSNORM NORMAS</p>	 <p><b>ANSI 137.1</b></p> <p>REQUISITI REQUIREMENTS CONDITIONS REQUISES VORAUSSETZUNGEN REQUISITOS</p>	
RESISTENZA AL GELO <i>FROST RESISTANCE RESISTANCE AU GEL FROSTBESTÄNDIGKEIT RESISTENCIA AL HIELO</i>		Applicabile	-	ASTM C 1026	Come indicato <i>As reported Comme indiqué ci dessus. Wie erwähnt Como indicado.</i>	-
ASSORBIMENTO D'ACQUA <i>WATER ABSORPTION ABSORPTION D'EAU WASSERAUFNAHME ABSORCIÓN DE AGUA</i>		≥ 10% medio	≥ 15%	ASTM C 373	7% < Ass H <sub>2</sub> O ≤20%	-
RESISTENZA ALLA FLESSIONE <i>BENDING STRENGTH RESISTANCE À LA FLEXION BIEGEFESTIGKEIT RESISTENCIA A LA FLEXIÓN</i>		≥ 12N/mm <sup>2</sup> sp ≥ 7,5	> 18	ASTM C 648	≥ 125 Lbf Val. singolo ≥ 100 Lbf	≥ 125 Lbf
DUREZZA SUPERFICIALE (SCALA MOHS) <i>MOHS' HARDNESS DURETÉ SUPERFICIELLE À LA RAYURE RITZHÄRTE DER OBERFLÄCHE DUREZA SUPERFICIAL (ESCALA MOHS)</i>		-	-	CTI - 81-7	-	-
DILATAZIONE TERMICA LINEARE <i>LINEAR THERMAL EXPANSION DILATATION THERMIQUE LINEAIRE LINEARE THERMISCHE AUSDEHNUNG DILATACIÓN TÉRMICA LINEAL</i>		Applicabile	-	ASTM C 372	-	-
RESISTENZA AL CAVILLO <i>RESISTANT TO GRAZING RESISTANCE À LA CRAQUÉLURE HAARRISSBESTÄNDIGKEIT RESISTENCIA A LAS GRIETAS</i>		Richiesta Required Demande Gefordert Solicitud	Resiste Resists Résiste Standhallet Resiste	ASTM C 424	Richiesta Required Demande Gefordert Solicitud	Resiste Resists Résiste Standhallet Resiste
RESISTENZA AGLI SBALZI TERMICI <i>RESISTANT TO THERMAL SHOCKS RESISTANCE AUX ÉCARTS DE TEMPÉRATURE THERMOSCHOCKBESTÄNDIGKEIT RESISTENCIA A LOS CAMBIOS BRUSCOS DE TEMPERATURA</i>		Applicabile	Resiste Resists Résiste Standhallet Resiste	ASTM C 484	Richiesta Required Demande Gefordert Solicitud	Resiste Resists Résiste Standhallet Resiste
RESISTENZA ALLE MACCHIE <i>RESISTANT TO STAINING RESISTANCE AUX TACHES FLECKENBESTÄNDIGKEIT RESISTENCIA A LAS MANCHAS</i>		GL = min Classe 3	5	ASTM C 1378	Come indicato <i>As reported Comme indiqué ci dessous. Wie erwähnt Como indicado.</i>	-
RESISTENZA ALL'ATTACCO CHIMICO <i>RESISTANT TO CHEMICAL ATTACK RESISTANCE AUX ATTAQUES CHIMIQUES RESISTENT GEGEN CHEMIKALIEN RESISTENCIA A LOS ATAQUES QUÍMICOS</i>		Min B - House hold chemicals Applicabile - Basse concentrazioni Applicabile - Alte concentrazioni	-	ASTM C 650	Come indicato <i>As reported Comme indiqué ci dessous. Wie erwähnt Como indicado.</i>	-

**Vista l'ampia gamma di prodotti i valori sopra riportati sono la media della gamma produttiva**  
Because the selection of products is very wide, the figures given above are the average for the product range - Etant donné la vaste gamme de produits les valeurs rapportées sont la moyenne de la gamme de production.  
Angesichts des großen Produktangebots sind die oben wiedergegebenen Werte Durchschnittswerte, die sich auf die gesamte Produktion beziehen - Dada la amplia gama de productos, los valores anteriormente mencionados son la media de la gama productiva.

pastorelli



Pastorelli S.p.A - Via Magazzino, 1944 - 41056 Savignano sul Panaro (MO) - ITALY  
Tel. +39.059.739.111 - Fax +39.059.796.291  
E-mail: [info@pastorellitiles.com](mailto:info@pastorellitiles.com)  
[www.pastorellitiles.com](http://www.pastorellitiles.com)



Ceramics of Italy